

Improved Linear (hull) Cryptanalysis of Round-reduced Versions of SIMON

Danping Shi^{1,2}, Lei Hu^{1,2*}, Siwei Sun^{1,2}, Ling Song^{1,2}, Kexin Qiao^{1,2},
Xiaoshuang Ma^{1,2}

¹State Key Laboratory of Information Security, Institute of Information Engineering,
Chinese Academy of Sciences, Beijing 100093, China

²Data Assurance and Communication Security Research Center,
Chinese Academy of Sciences, Beijing 100093, China
{dpshi, hu, swsun, lsong, kxqiao13, xshma13}@is.ac.cn

December 12, 2014

Abstract. SIMON is a family of lightweight block ciphers designed by the U.S. National Security Agency (NSA) that has attracted much attention since its publication in 2013. In this paper, we thoroughly investigate the properties of linear approximations of the bitwise AND operation with dependent input bits. By using a Mixed-integer Linear Programming based technique presented in Aasicrypt 2014 for automatic search for characteristics, we obtain improved linear characteristics for several versions of the SIMON family. Moreover, by employing a recently published method for automatic enumeration of differential and linear characteristics by Sun *et. al.*, we present an improved linear hull analysis of some versions of the SIMON family, which are the best results for linear cryptanalysis of SIMON published so far.

Specifically, for SIMON128, where the number denotes the block length, a 34-round linear characteristic with correlation 2^{-61} is found, which is the longest linear characteristic that can be used in a key-recovery attack for SIMON128 published so far. Besides, several linear hulls superior to the best ones known previously are presented as follows: linear hulls for the 13-round SIMON32 with *potential* $2^{-28.99}$ versus previous $2^{-31.69}$, for the 15-round SIMON48 with *potential* $2^{-42.28}$ versus previous $2^{-44.11}$ and linear hulls for the 21-round SIMON64 with *potential* $2^{-60.72}$ versus previous $2^{-62.53}$.

Keywords. SIMON, linear cryptanalysis, linear hull, key recovery

1 Introduction

SIMON is a family of lightweight block ciphers presented by the U.S. National Security Agency [4] with a feistel structure of different versions of block and key lengths. By far, SIMON has attracted many cryptanalysis such as differential analysis [1, 5, 11, 12], linear cryptanalysis [2, 3], impossible differential and zero-correlation linear hull cryptanalysis [2, 13].

Linear cryptanalysis [7] presented by Matsui is an important cryptanalysis method on block ciphers. It aims at finding a linear expression involving bits of plaintexts, “ciphertexts” (including inner states) and subkeys that deviates from a random linear expression. A key recovery attack can then be launched due to this nonrandomness. Linear expressions are usually obtained by linear characteristics that consists of masks for each round state and applies the piling-up lemma to concatenate. This method has been extended to linear hull cryptanalysis by Nyberg [8] in 1995 when several linear characteristics with same input and output masks are used. In this paper, we investigate linear characteristics with consideration of dependences of the S-boxes. By the methods of automatic enumeration of differential and linear characteristics presented in [10, 11], some improved results about the linear (hull) cryptanalysis are obtained in this paper.

Specifically, the longest linear characteristic known previously for key recovery on SIMON128 shown in paper [3] is a 34-round linear characteristic with correlation 2^{-63} while we present one with correlation 2^{-61} in this paper. Furthermore, the latter can be used to attack SIMON by Matsui’s Algorithm 2 with the complexity 2^{127} and probability of success 97% according to the calculating method in [9]. Besides, for SIMON32 the best linear hull known previously is a 13-round one with *potential* $2^{-31.69}$ in [3] while we give one with *potential* $2^{-28.99}$ in this paper. Moreover, a 15-round linear hull for SIMON48 with *potential* $2^{-42.28}$ is presented, whereas the 15-round linear hull with *potential* $2^{-44.11}$ proposed in paper [3] was the previous best result for this version. We also find a 21-round linear hull with *potential* $2^{-60.72}$ and a 22-round linear hull with *potential* $2^{-63.83}$ for SIMON64. The previous best linear hull for SIMON64 is a 21-round linear hull with *potential* $2^{-62.53}$ proposed in paper [3]. The results are summarized in Table 1.

Table 1. Summary on improvement of the best linear characteristic/hulls.

Version	# Rounds	Correlation	Reference
SIMON128	34	2^{-63}	[3]
	34	2^{-61}	This paper
Version	# Rounds	<i>Potential</i>	Reference
SIMON32	13	$2^{-31.69}$	[3]
	13	$2^{-28.99}$	This paper
SIMON48	15	$2^{-44.11}$	[3]
	15	$2^{-42.28}$	This paper
SIMON64	21	$2^{-62.53}$	[3]
	21	$2^{-60.72}$	This paper
	22	$2^{-63.83}$	This paper

Rounds: Number of rounds for linear characteristic/hulls.

The paper is organized as follows. Section 2 gives a brief description of the block cipher SIMON. Section 3 presents a linear cryptanalysis as well as a linear characteristic/hull searching method on SIMON. The improved results with the linear (hull) cryptanalysis are given in Section 4. We finally conclude the paper in Section 5.

2 Brief description of SIMON

The SIMON $2n/mn$ is a feistel structure block cipher with $(2n)$ -bit block length and (mn) -bit key length, where n could be 16, 24, 32, 48, or 64 and m is required to be 2, 3, 4. All versions of SIMON with corresponding number of rounds are listed in Table 2. Before a further description of SIMON, we give the notations used in the paper.

Table 2. Versions of SIMON

Block size ($2n$)	Key size (mn)	Total rounds
32	64	32
48	72	36
	96	36
64	96	42
	128	44
96	96	52
	144	54
128	128	68
	192	69
	256	72

2.1 Notations

L^r : left half n -bit input for the r -th round

R^r : right half n -bit input for the r -th round

K^r : subkey for the r -th round

$X[j]$: the $(j \bmod n)$ -th bit of X , where $X[1]$ is the MSB of X

n_k : the length of the master key

$X \lll i$: left circular shift by i bits of X

\oplus : bitwise XOR

\wedge : bitwise AND

2.2 Round function of SIMON

The round function of SIMON is shown as follows:

$$\begin{aligned} L^{r+1} &= R^r \oplus K^r \oplus (L^r \lll 2) \oplus ((L^r \lll 1) \wedge (L^r \lll 8)) \\ R^{r+1} &= L^r \end{aligned}$$

We only consider single key cryptanalysis in this paper thus the key schedule is omitted here. More details on SIMON can be found in paper [4].

3 Linear cryptanalysis of SIMON

A linear approximation of bits in plaintexts, ciphertexts and subkeys is a Boolean function and we use correlation and bias to evaluate it. Let $f : GF(2)^n \rightarrow GF(2)$ be a Boolean function. The correlation ϵ_f of f is defined by

$$2^{-n} \cdot (\#\{x \in GF(2)^n : f(x) = 0\} - \#\{x \in GF(2)^n : f(x) = 1\})$$

and $\delta_f = 1/2 \cdot \epsilon_f$ is denoted as the bias of f . We have $\delta_f = 2^{-n}(\#\{f(x) = 0\}) - 1/2$. The higher is the magnitude of the correlation, $|\epsilon_f|$, the fewer plaintexts are needed in a linear attack.

Nyberg defined the *potential* of a linear hull with the input and output masks α and β for a block cipher $C = f(P, K)$ in [8] as follows:

$$ALH(\alpha, \beta) = \sum_{\gamma} (Pr(\alpha \cdot P + \beta \cdot C + \gamma \cdot K = 0) - 1/2)^2. \quad (1)$$

Similarly, a linear hull with a higher potential value leads to a better linear attack as fewer plaintexts are required.

3.1 Linear approximation of bitwise AND

We denote the unique non-linear layer in the round function of SIMON by

$$f^N(L^r) = (L^r \lll 1) \wedge (L^r \lll 8).$$

Regarding each bitwise \wedge as a 2×1 S-box, the function f^N is composed of n 2×1 S-boxes with inputs $L^r[j+1]$ and $L^r[j+8]$, denoted by

$$f_j^N(L^r[j+1], L^r[j+8]) = L^r[j+1] \wedge L^r[j+8].$$

Consider the linear approximation of the function f_i^N with two input mask bits and one output mask bit. It is easily calculated that magnitude of the correlation of a linear approximation of a 2×1 S-box is 2^{-1} if it is with a non-zero output mask, is 0 if it is with the non-zero input mask and the zero output mask, and is 1 if it is with the all-zero input and output. Thus, the number of active S-boxes is the sum of the Hamming weights of output masks of the S-box layers for SIMON, where an active S-box means it is with a non-zero output mask.

3.2 Dependences of S-boxes

As shown in [10], the dependence of active S-boxes should be taken into consideration in linear cryptanalysis. Here we illustrate it by an example.

Let Y^r be the output value of the nonlinear function f^N in round r , I_1^r and I_8^r be the input masks and O^r the output mask. Suppose two S-boxes f_{j+7}^N and f_{j+7}^N are active in one round, we have a linear approximation

$$I_1^r[j] \cdot L^r[j+1] \oplus I_8^r[j] \cdot L^r[j+8] \oplus Y^r[j] \oplus I_1^r[j+7] \cdot L^r[j+8] \oplus I_8^r[j+7] \cdot L^r[j+15] \oplus Y^r[j+7] \quad (2)$$

with correlation 0 or $\pm 2^{-1}$, instead of $\pm 2^{-2}$ by the piling-up lemma [7]. The invalid application of the piling-up lemma is due to the dependence of the two S-boxes, namely both of them take $L^r[j+8]$ as input. We should take the dependence seriously as it may invalidate a linear characteristic by correlation 0. In the following, we scrutinize the relationship between the input variables of active S-boxes and the correlation of the corresponding expression.

Firstly, the input masks (I_1^r, I_8^r) of f^N determine whether the correlation of an approximation is zero or not. For non-zero cases, the output mask determines the absolute value of the correlation. This property comes from a fact on quadratic Boolean functions as follows.

Consider a Boolean function

$$f : \mathbb{F}_2 \times \mathbb{F}_2 \times \cdots \times \mathbb{F}_2 \rightarrow \mathbb{F}_2$$

$$(x_1, x_2, \cdots, x_n) \rightarrow L_x(x_1, x_2, \cdots, x_n) + B_x(x_1, x_2, \cdots, x_n),$$

where $L_x(x_1, x_2, \cdots, x_n)$ is linear and $B_x(x_1, x_2, \cdots, x_n)$ is sum of quadratic terms $x_i \cdot x_j$ and $x_i, x_j \in GF(2)$. A new quadratic form

$$g : \mathbb{F}_2 \times \mathbb{F}_2 \times \cdots \times \mathbb{F}_2 \rightarrow \mathbb{F}_2$$

$$(y_1, y_2, \cdots, y_n) \rightarrow L_y(y_1, y_2, \cdots, y_n) + B_y(y_1, y_2, \cdots, y_n),$$

retaining the same correlation is obtained from $f(x_1, x_2, \cdots, x_n)$ by a nonsingular linear transform $y = A * x$, where $L_y(y_1, y_2, \cdots, y_n) = y_{j_1} + y_{j_2} + \cdots + y_{j_t}$ and $B_y(y_1, y_2, \cdots, y_n) = y_{i_1} \cdot y_{i_2} + y_{i_3} \cdot y_{i_4} + \cdots + y_{i_{2s-1}} \cdot y_{i_{2s}}$ with all subscripts i_1, i_2, \cdots, i_{2s} not coincident. The absolute value of the correlation of the linear approximation of g is 0 if $\{j_1, j_2, \cdots, j_t\} \setminus \{i_1, i_2, \cdots, i_{2s}\}$ is non-empty or 2^{-s} if $\{j_1, j_2, \cdots, j_t\} \subseteq \{i_1, i_2, \cdots, i_{2s}\}$. In the latter case, therefore, less variables involved in quadratic terms result in greater absolute value of correlation.

The linear approximation of S-box layer in the r -th round of SIMON is

$$G : \mathbb{F}_2 \times \mathbb{F}_2 \times \cdots \times \mathbb{F}_2 \rightarrow \mathbb{F}_2$$

$$(L^r[1], L^r[2], \cdots, L^r[n]) \rightarrow L_G(L^r[1], L^r[2], \cdots, L^r[n]) + B_G(L^r[1], L^r[2], \cdots, L^r[n]),$$

where

$$L_G(L^r[1], L^r[2], \cdots, L^r[n]) = \sum_{j=1}^n (I_1^r[j] \cdot L^r[j+1] + I_8^r[j] \cdot L^r[j+8]),$$

$$B_G(L^r[1], L^r[2], \cdots, L^r[n]) = \sum_{j=1}^n O^r[j] \cdot (L^r[j+1] \cdot L^r[j+8]).$$

and its correlation should be calculated following the above rules.

3.3 Description of automatic enumeration of characteristics with MILP

Automatic search of differential characteristic for bit-oriented block ciphers by Mixed-integer Linear Programming (MILP) modelling was investigated by Sun *et al.* [11], which extended the method to automatic search linear characteristic and linear hull in [10]. This kind of methods denotes each mask bit as a 0-1 variable and describes their propagation through the cipher as linear inequalities (constraints) subjected to which an optimized value of number of active S-boxes is returned. Specifically, the MILP model is as follows.

Constraints for linear operation.

These three constraints for linear operation can be directly obtained from paper [6, 10].

1. For each bitwise XOR operation, (α_1, α_2) and β denote the input masks and output mask of \oplus . The constraints of these mask bits are:

$$\alpha_1 = \alpha_2 = \alpha_3. \quad (3)$$

2. For each branching in the cipher structure, let $(\alpha_1, \alpha_2, \alpha_3)$ denote the masks on three branches. The constraints of the masks are:

$$\begin{cases} \tau \geq \alpha_1, \tau \geq \alpha_2, \tau \geq \alpha_3; \\ \alpha_1 + \alpha_2 + \alpha_3 \geq 2\tau; \\ \alpha_1 + \alpha_2 + \alpha_3 \leq 2. \end{cases} \quad (4)$$

where τ is a dummy variable.

3. For operation of left circular shift by i bits, let $\mu = (\mu[1], \mu[2], \dots, \mu[n])$ and $\nu = (\nu[1], \nu[2], \dots, \nu[n])$ be the input and output masks. The constraints of the masks are:

$$\nu[j] = \mu[j + i], j \in \{1, 2, \dots, n\} \quad (5)$$

Constraints for S-box.

The S-box in SIMON is bitwise AND and to get valid linear characteristics we only allow the active S-boxes with non-zero output masks and inactive S-boxes with all zero masks. This rule can be described as:

$$\begin{cases} O^r[j] \geq I_1^r[j], \\ O^r[j] \geq I_8^r[j], \end{cases} \quad (6)$$

where the symbols are as mentioned earlier. The constraint (6) also means that the output mask must be non-zero if the input mask is non-zero.

Constraints dealing with dependences of S-boxes.

As presented in Section 3.2, given the masks $(I_1^r, I_8^r), O^r$ for the S-box layer in one round, a smaller number of variables involved in quadratic terms leads to

a bigger absolute value of the correlation of G . In this paper, we want to find the masks that lead to the least number of variables appearing in quadratic terms. To indicate the number of variables in quadratic terms of the linear approximation of f^N , n new 0-1 variables $V^r[j]$ ($j \in \{1, 2, \dots, n\}$) indicating whether $L^r[j]$ exists in the quadratic terms are introduced in each round for SIMON. The constraints are

$$\begin{cases} V^r[j] \geq O^r[j - 1], \\ V^r[j] \geq O^r[j - 8], \\ V^r[j] \leq O^r[j - 1] + O^r[j - 8]. \end{cases} \quad (7)$$

Thus, $\sum_{j=1}^n V^r[j]$ is the number of variables appearing in quadratic terms of the linear approximation for one round and $\sum_r \sum_{j=1}^n V^r[j]$ is the number of variables appearing in the linear approximation of SIMON. Note that linear characteristics with the same number of active S-boxes may have different correlations due to different cases of dependences of active S-boxes.

Objective function.

To get the minimum number of linearly active S-boxes, the objective function is set to be the sum of all output mask bits of S-box layers in [10]. However, it is the correlation of the linear characteristics that determines the effectiveness of the linear cryptanalysis. Therefore, considering the influence of the dependence of active S-boxes on correlation, we set the objective function to be $\sum_r \sum_{j=1}^n V^r[j]$.

With the constraints and the objective function defined above, we try to find better linear characteristics and linear hulls for SIMON with Gurobi, a solver for MILP models. The linear characteristics found may has correlation value 0 due to the dependence of active S-boxes. It is imperative to test whether the linear characteristic has correlation 0.

Constraints for linear hulls.

To get linear hulls, we set the input and output mask bits as the ones in a known linear characterisic and get an amount of linear characteristics that form a linear hull.

4 Results

For each linear characteristic, we obtain the accurate absolute value of the correlation of the linear approximation for each round by nonsingular transform method shown in Section 3.2. After getting the correlation in each round, apply the piling-up lemma to obtain the absolute value of the correlation of the whole cipher since S-boxes from different rounds can be seen as independent ones with the effect of round keys. The results are as follows.

4.1 Linear characteristic

Experiments have been done on SIMON128. A 34-round linear characteristic of SIMON128 with bias 2^{-62} for a key recovery attack has been found. To the best of our knowledge, the best 34-round characteristic of SIMON128 known previously is presented in [3] and has the bias 2^{-64} . What is more, all active S-boxes in this characteristic are independent according to our test. Besides, this characteristic of SIMON128 with bias 2^{-62} is the linear characteristic that covers most rounds and simultaneously meets the condition of $\delta \geq 2^{-n+2}$, which indicates that the probability of success for key recovery is 0.997 [9]. The previous best result that satisfies the condition is a 33-round characteristic with bias 2^{-60} in [3]. The linear mask (separated into left and right parts) is presented in Tables 5 and 6 in Appendix.

Our characteristic can be used to attack 36-round SIMON128 with data complexity 2^{124} and time complexity 2^{124} by Matsui’s algorithm 1 [7], and can be further extended to attack 43 rounds with data complexity 2^{127} with probability of success 0.997 by Matsui’s algorithm 2 [7, 9]. The latter is demonstrated in Figure 1 where the 60 bits of subkeys numbered in black need to be guessed and the red ones not.

For SIMON64, a 18-round linear characteristic with bias 2^{-32} is listed in Table 7 and Table 8 in Appendix. The longest linear characteristic known previously with absolute value of bias no less than 2^{-32} is a 17-round linear characteristic with bias 2^{-29} presented in [3]. The comparison between our results and the results presented in [3] is in Table 3. Characteristics for SIMON32, SIMON48 are listed in Tables 9-12 in Appendix.

Table 3. The comparison between this paper and others.

Version	‡ Rounds	Bias	Reference
SIMON64	17	2^{-29}	[3]
	18	2^{-32}	This paper
SIMON128	34	2^{-64}	[3]
	34	2^{-62}	This paper

‡ Rounds: Number of rounds for linear characteristic.

4.2 Linear hull

By setting the input and output masks same as the characteristic in Table 9 and Table 10 with an added constraint $\sum_r \sum_{j=1}^n V^r[j] \leq 45$, we find a 13-round linear hull with *potential* $2^{-28.99}$ for SIMON32. To our knowledge, the best previously found linear hull for SIMON32 was a 13-round linear hull presented in paper

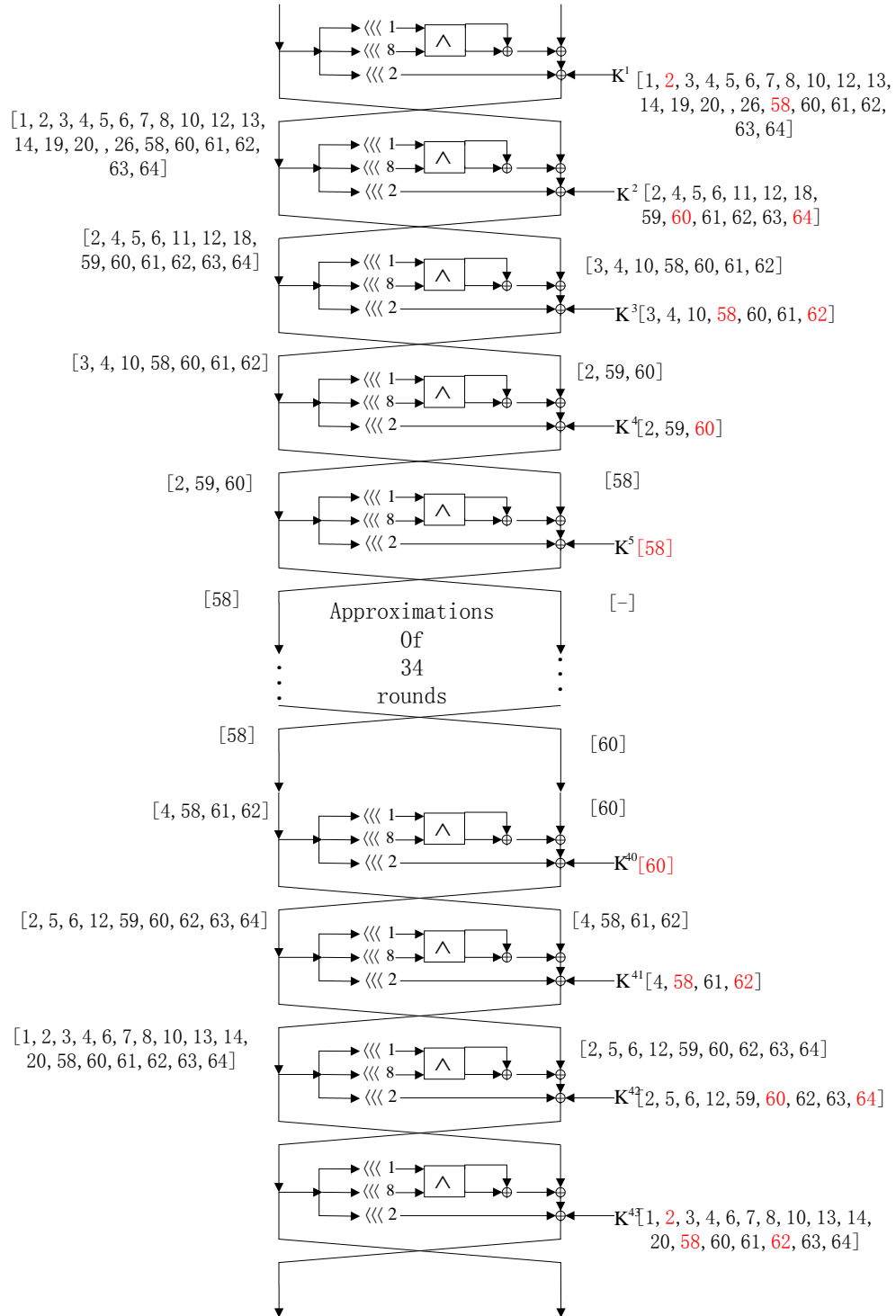

Fig. 1. Linear cryptanalysis of SIMON128/192

[3] with *potential* $2^{-31.69}$. Actually, 412206 linear characteristics are returned in our model, among which only 196474 have non-zero correlation while others are zero due to the dependence of active S-boxes. Dependence of active S-boxes also exerts influence on valid characteristics. For example, the linear characteristic presented in Table 9 and Table 10 is with correlation 2^{-18} but with 19 active S-boxes. Further, this linear hull can be used to attack 21 rounds for SIMON32/64 as Figure 2 shows with success probability 97%. The number of the bits guessed for the key is 32.

A 15-round linear hull with *potential* $2^{-42.28}$ for SIMON48 is obtained by setting input and output masks same as the characteristic shown in Table 11 and Table 12, with an additional constraint $\sum_r \sum_{j=1}^n V^r[j] \leq 59$. As we know, the best previously found linear hull for SIMON48 was a 15-round linear hull presented in paper [3] with *potential* $2^{-44.11}$. Actually, 50432 linear characteristics are returned among which only 43524 are valid. This linear hull can be used to attack 21 rounds for SIMON48/96 with success probability 97% as Figure 3 shows. The number of the bits guessed for the key is 51.

A 21-round linear hull with *potential* $2^{-60.72}$ for SIMON64 is obtained whereas the previous best linear hull for this version is a 21-round linear characteristic with *potential* $2^{-62.53}$ [3]. Among the 115199 linear characteristics found with additional constraint $\sum_r \sum_{j=1}^n V^r[j] \leq 78$, 63996 have non-zero bias. This linear hull can be used to attack 29 rounds for SIMON64/128 demonstrated in Figure 4 achieving success probability 97%. The number of the guessed bits of key is 63. The masks listed in Table 13 and Table 14 in Appendix is a linear characteristic with bias 2^{-36} . Besides, a 22-round linear hull with *potential* $2^{-63.83}$ for SIMON64 is found in this paper, with the input and output masks same with the linear characteristic listed in Table 15 and Table 16 in Appendix.

Summary of the results about linear hulls in this paper is presented in Table 4.

Table 4. Summary of results with linear hull.

Version	# Rounds	<i>potential</i>	# Returned	# Valid	# Attacked	Reference
SIMON32/64	13	$2^{-31.69}$	-	-	20	[3]
	13	$2^{-28.99}$	412206	196474	21	This paper
SIMON48/96	15	$2^{-44.11}$	-	-	20	[3]
	15	$2^{-42.28}$	50432	43524	21	This paper
SIMON64/128	21	$2^{-62.53}$	-	-	28	[3]
	21	$2^{-60.72}$	115199	63996	29	This paper
	22	$2^{-63.83}$	52840	28590		This paper

Rounds: Number of rounds for linear hull.

Returned: Number of characteristics returned by the model.

Valid: Number of characteristics with non-zero correlation.

Attacked: Number of attacked rounds.

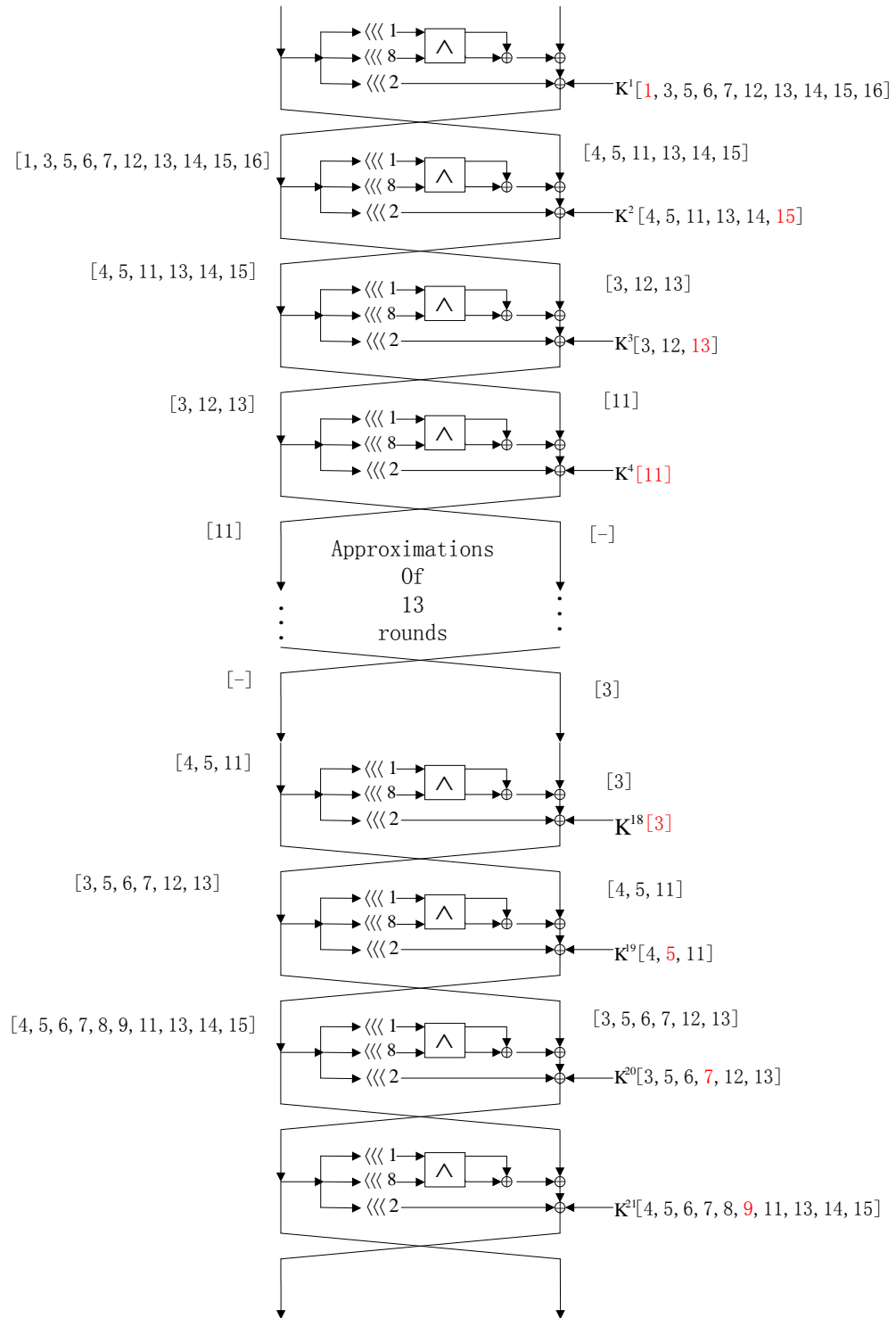

Fig. 2. Linear hull cryptanalysis of SIMON32/62

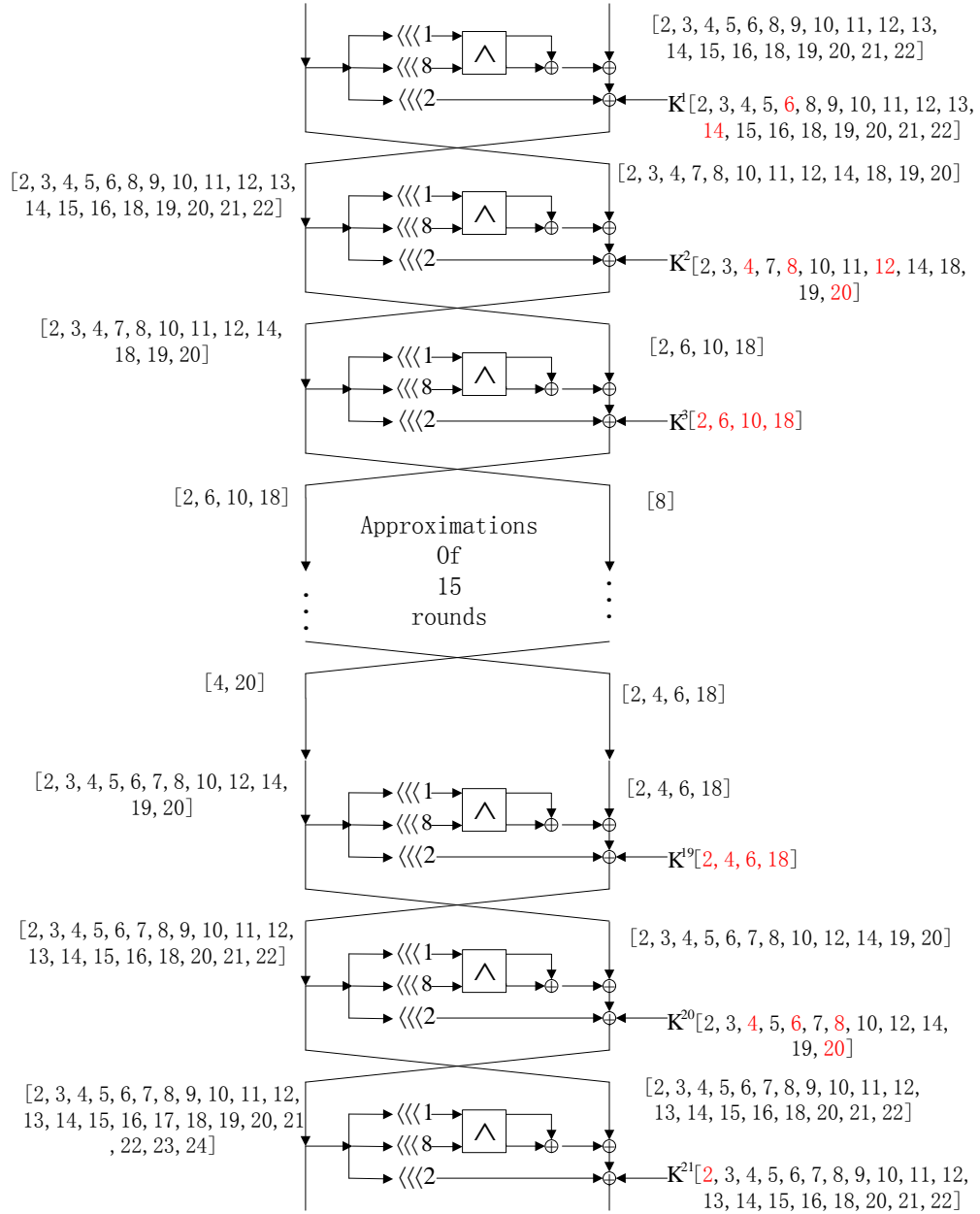

Fig. 3. Linear hull cryptanalysis of SIMON48/96

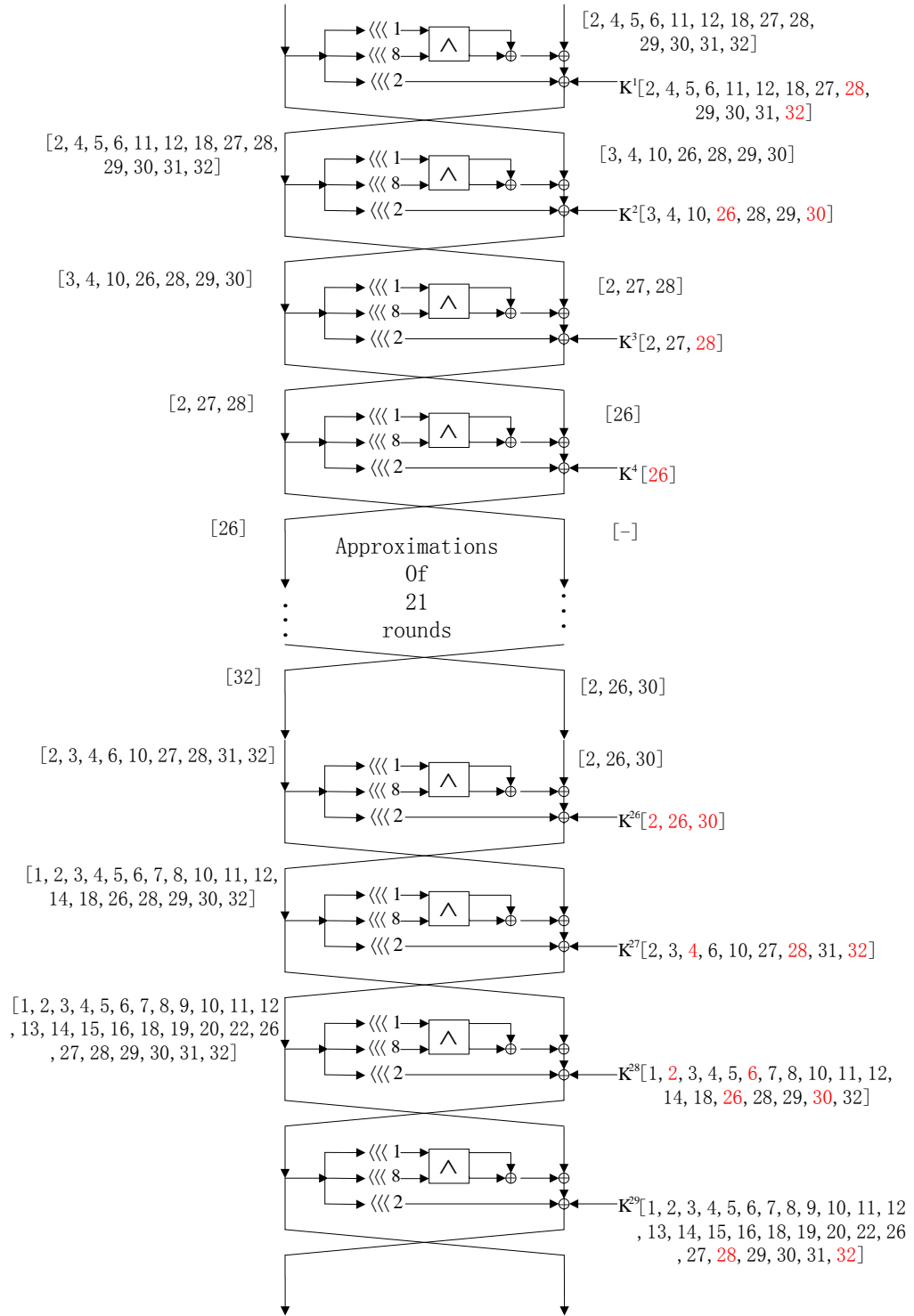

Fig. 4. Linear hull cryptanalysis of SIMON64/128

5 Conclusion

In this paper, we considered the dependence of S-boxes in the evaluation of correlation of a linear approximation. With an automatic enumeration of the differential and linear characteristic, improved results on the linear (hull) cryptanalysis on SIMON were obtained. Simply, the 34-round linear characteristic with correlation 2^{-61} on SIMON128 presented in this paper is the best linear characteristic as we know. Besides, a 13-round linear hull with *potential* $2^{-30.19}$ for SIMON32, a 15-round linear hull with *potential* $2^{-42.28}$ for SIMON48, a 21-round linear hull with *potential* $2^{-61.10}$ and a 22-round linear hull with *potential* $2^{-63.83}$ for SIMON64 were presented in this paper.

References

1. Farzaneh Abed, E List, J Wenzel, and S Lucks. Differential cryptanalysis of round-reduced simon and speck. *Preproceedings of Fast Software Encryption (FSE 2014)(2014, to appear)*, 2014.
2. Javad Alizadeh, Hoda A Alkhzaimi, Mohammad Reza Aref, Nasour Bagheri, Praveen Gauravaram, Abhishek Kumar, Martin M Lauridsen, and Somitra Kumar Sanadhya. Cryptanalysis of simon variants with connections. In *Radio Frequency Identification: Security and Privacy Issues*, pages 90–107. Springer, 2014.
3. Javad Alizadeh, Hoda A Alkhzaimi, Mohammad Reza Aref, Nasour Bagheri, Praveen Gauravaram, and Martin M Lauridsen. Improved linear cryptanalysis of round reduced simon. Technical report, IACR Cryptology ePrint Archive, Reprint 2014/681, 2014. <http://eprint.iacr.org/2014/681>. pdf.
4. Ray Beaulieu, Douglas Shors, Jason Smith, Stefan Treatman-Clark, Bryan Weeks, and Louis Wingers. The simon and speck families of lightweight block ciphers. *IACR Cryptology ePrint Archive*, 2013:404, 2013.
5. Alex Biryukov, Arnab Roy, and Vesselin Velichkov. Differential analysis of block ciphers simon and speck. In *International Workshop on Fast Software Encryption-FSE*, 2014.
6. Andrey Bogdanov and Vincent Rijmen. Linear hulls with correlation zero and linear cryptanalysis of block ciphers. *Designs, Codes and Cryptography*, 70(3):369–383, 2014.
7. Mitsuru Matsui. Linear cryptanalysis method for des cipher. In Tor Helleseth, editor, *Advances in Cryptology ?EUROCRYPT ?3*, volume 765 of *Lecture Notes in Computer Science*, pages 386–397. Springer Berlin Heidelberg, 1994.
8. Kaisa Nyberg. Linear approximation of block ciphers. In *Advances in CryptologyEUROCRYPT'94*, pages 439–444. Springer, 1995.
9. Ali Aydın Selçuk. On probability of success in linear and differential cryptanalysis. *Journal of Cryptology*, 21(1):131–147, 2008.
10. Siwei Sun, Lei Hu, Meiqin Wang, Peng Wang, Kexin Qiao, Xiaoshuang Ma, Daping Shi, and Ling Song. Automatic enumeration of (related-key) differential and linear characteristics with predefined properties and its applications.
11. Siwei Sun, Lei Hu, Peng Wang, Kexin Qiao, Xiaoshuang Ma, and Ling Song. Automatic security evaluation and (related-key) differential characteristic search: Application to simon, present, lblock, des(1) and other bit-oriented block ciphers. In Palash Sarkar and Tetsu Iwata, editors, *Advances in Cryptology ?ASIACRYPT*

- 2014, volume 8873 of *Lecture Notes in Computer Science*, pages 158–178. Springer Berlin Heidelberg, 2014.
12. Ning Wang, Xiaoyun Wang, Keting Jia, and Jingyuan Zhao. Improved differential attacks on reduced simon versions. Technical report, Cryptology ePrint Archive, Report 2014/448, 2014.
 13. Qingju Wang, Zhiqiang Liu, Kerem Varıcı, Yu Sasaki, Vincent Rijmen, and Yosuke Todo. Cryptanalysis of reduced-round simon32 and simon48. In *Progress in Cryptology–INDOCRYPT 2014*, pages 143–160. Springer, 2014.

6 Appendix

Table 9. The left mask of 13-round linear characteristic for SIMON32

Rounds	The input linear mask of the left half
0	00000000010000
1	00000000000000
2	00000000010000
3	00000000000100
4	00000000010010
5	10000000000000
6	00100000010010
7	00001000001100
8	00100010001000
9	00000000100000
10	00100010000000
11	00001000000000
12	00100000000000
13	00000000000000

Table 10. The right mask of 13-round linear characteristic for SIMON32

Rounds	The input linear mask of the right half
0	00000000000000
1	00000000010000
2	00000000000100
3	00000000010010
4	10000000000000
5	00100000010010
6	00001000001100
7	00100010001000
8	00000000100000
9	00100010000000
10	00001000000000
11	00100000000000
12	00000000000000
13	00100000000000

Table 11. The left mask of 15-round linear characteristic for SIMON48

Rounds	The input linear mask of the left half
0	010001000100000001000000
1	000000010000000000000000
2	010001000000000001000000
3	000100000000000000010000
4	010000000000000001000100
5	000000000000000000000001
6	000000000000000001000100
7	0000000000000000010000
8	000000000000000001000000
9	000000000000000000000000
10	000000000000000001000000
11	0000000000000000010000
12	000000000000000001000100
13	000000000000000000000001
14	010000000000000001000100
15	0001000000000000010000

Table 12. The right mask of 15-round linear characteristic for SIMON48

Rounds	The input linear mask of the right half
0	000000010000000000000000
1	010001000000000001000000
2	0001000000000000010000
3	010000000000000001000100
4	000000000000000000000001
5	000000000000000001000100
6	0000000000000000010000
7	000000000000000001000000
8	000000000000000000000000
9	000000000000000001000000
10	0000000000000000010000
11	000000000000000001000100
12	000000000000000000000001
13	010000000000000001000100
14	0001000000000000010000
15	010101000000000001000000

