

# New Constructions of Identity-Based and Key-Dependent Message Secure Encryption Schemes <sup>\*</sup>

Nico Döttling<sup>1</sup>, Sanjam Garg<sup>2</sup>, Mohammad Hajiabadi<sup>2</sup>, and Daniel Masny<sup>2</sup>

<sup>1</sup> Friedrich-Alexander-University Erlangen-Nürnberg

<sup>2</sup> University of California, Berkeley

{nico.doettling, sanjamg, daniel.masny}@berkeley.edu

**Abstract.** Recently, Döttling and Garg (CRYPTO 2017) showed how to build identity-based encryption (IBE) from a novel primitive termed *Chameleon Encryption*, which can in turn be realized from simple number theoretic hardness assumptions such as the computational Diffie-Hellman assumption (in groups without pairings) or the factoring assumption. In a follow-up work (TCC 2017), the same authors showed that IBE can also be constructed from a slightly weaker primitive called *One-Time Signatures with Encryption* (OTSE).

In this work, we show that OTSE can be instantiated from hard learning problems such as the Learning With Errors (LWE) and the Learning Parity with Noise (LPN) problems. This immediately yields the first IBE construction from the LPN problem and a construction based on a weaker LWE assumption compared to previous works.

Finally, we show that the notion of one-time signatures with encryption is also useful for the construction of key-dependent-message (KDM) secure public-key encryption. In particular, our results imply that a KDM-secure public key encryption can be constructed from any KDM-secure secret-key encryption scheme and any public-key encryption scheme.

---

<sup>\*</sup> Research supported in part from 2017 AFOSR YIP Award, DARPA/ARL SAFEWARE Award W911NF15C0210, AFOSR Award FA9550-15-1-0274, NSF CRII Award 1464397, and research grants by the Okawa Foundation, Visa Inc., and Center for Long-Term Cybersecurity (CLTC, UC Berkeley). The views expressed are those of the author and do not reflect the official policy or position of the funding agencies.

## 1 Introduction

Identity-based encryption (IBE) is a form of public key encryption that allows a sender to encrypt messages to a user without knowing a user-specific public key, but only the user’s name or identity and some global and succinct public parameters. The public parameters are issued by a key authority which also provides identity-specific secret keys to the users.

The notion of IBE was originally proposed by Shamir [Sha84], and in two seminal results Boneh and Franklin [BF01] and Cocks [Coc01] provided the first candidate constructions of IBE in the random oracle model from groups with pairings and the quadratic residue problem respectively. Later works on IBE provided security proofs without random oracles [BF01, BB04, Wat05, Wat09, LW10, BGH07] and realized IBE from hard lattice problems [GPV08, CHKP12, ABB10].

In a recent result, Döttling and Garg [DG17b] showed how to construct IBE from (presumably) qualitatively simpler assumptions, namely the computational Diffie-Hellman assumption in groups without pairings or the factoring assumption. In a follow-up work, the same authors [DG17a] provided a generalization of the framework proposed in [DG17b]. In particular, the authors show that identity-based encryption is equivalent to the seemingly simpler notion of *One-Time Signatures with Encryption* (OTSE) using a refined version of the tree-based IBE construction of [DG17b].

An OTSE-scheme is a one-time signature scheme with an additional encryption and decryption functionality. Informally, the encryption functionality allows anyone to encrypt a plaintext  $m$  to a tuple consisting of a public parameter  $\mathbf{pp}$ , a verification key  $\mathbf{vk}$ , an index  $i$  and a bit  $b$ , to obtain a ciphertext  $c$ . The plaintext  $m$  can be deciphered from  $c$  by using a pair of message-signature  $(x, \sigma)$  that is valid relative to  $\mathbf{vk}$  and that  $x_i = b$ . Security of the OTSE asserts that an adversary knowing a pair of message-signature  $(x, \sigma)$  and the underlying public parameter  $\mathbf{pp}$  and verification key  $\mathbf{vk}$  cannot distinguish between encryptions of two plaintexts encrypted to  $(i, 1 - x_i)$  under  $(\mathbf{pp}, \mathbf{vk})$ , for any index  $i$  of the adversary’s choice. (Note that this security property implies the one-time unforgeability of the signature.) The OTSE also needs to be compact, meaning the size of the verification key grows only with the security parameter, and does not depend on the size of messages allowed to be signed.

## 1.1 PKE and IBE from Learning with Errors

We will briefly review constructions of public-key encryption and identity-based encryption from the Learning with Errors (LWE) problem.

The hardness of LWE is determined by its dimension  $n$ , modulus  $q$ , noise magnitude parameter  $\alpha$  and the amount of samples  $m$ . Regev [Reg05] showed that among the latter three parameters, in particular the noise magnitude parameter  $\alpha$  is of major importance since it directly impacts the approximation factor of the underlying lattice problem.

**Theorem 1 ([Reg05]).** *Let  $\epsilon = \epsilon(n)$  be some negligible function of  $n$ . Also, let  $\alpha = \alpha(n) \in (0, 1)$  be some real and let  $p = p(n)$  be some integer such that  $\alpha p > 2\sqrt{n}$ . Assume there exists an efficient (possibly quantum) algorithm that solves  $LWE_{p,\alpha}$ . Then there exists an efficient quantum algorithm for solving the following worst-case lattice problems:*

1. Find a set of  $n$  linearly independent lattice vectors of length at most  $\tilde{O}(\lambda_n(L) \cdot n/\alpha)$ .
2. Approximate  $\lambda_1(L)$  within  $\tilde{O}(n/\alpha)$ .

Here,  $\lambda_k$  is the minimal length of  $k$  linearly independent vectors in lattice  $L$ . To find such vectors within a constant or slightly sublinear approximation is known to be NP-hard under randomized reductions [ABSS93, Ajt98, Mic98, Kho04, HR07], while for an exponential approximation factor, they can be found in polynomial time using the LLL algorithm [LLL82]. Regev [Reg05] introduced the first PKE based on LWE for a choice of  $\alpha = \tilde{O}(1/\sqrt{n})$ , more precisely  $\alpha = 1/(\sqrt{n} \log^2 n)$ . The first lattice based IBEs, by Gentry et. al. [GPV08], Cash et. al. [CHKP10] and by Agrawal et. al. [ABB10] require  $\alpha = \tilde{O}(1/n)$ ,  $\alpha = \tilde{O}(1/(\sqrt{kn}))$ , where  $k$  is the output length of a hash function, and  $\alpha = \tilde{O}(1/n^2)$ .

The reason for this gap between PKE and IBE is that all the known IBE constructions use an additional trapdoor in order to sample short vectors as secret keys. This sampling procedure increase the norm of sampled vectors, such that the initial noise of a ciphertext must be decreased to maintain the correctness of the schemes. By losing a factor  $\sqrt{n}$  in the sampling procedure [MR04, GPV08, MP12, LW15],  $\alpha$  needs to be chosen by a factor  $\sqrt{n}$  smaller. Therefore, this methodology unavoidably loses at least an additional  $\sqrt{n}$  factor. This explains why these techniques cause a gap compared to Regev's PKE where  $\alpha$  is at least a factor  $\sqrt{n}$  larger, which decreases the approximation factor by at least a factor of  $\sqrt{n}$ . This results in a substantially harder underlying short vector problem.

## 1.2 Our Results

As the main contribution of this work, we remove the requirement of the collision tractability property of the hash function in the construction of [DG]. Specifically, we replace the notion of Chameleon Encryption with the simpler notion of *Hash Encryption*, for which no collision tractability property is required. The notion of Hash Encryption naturally arises from the notion of laconic Oblivious Transfer [CDG<sup>+</sup>17]. We provide simple and efficient constructions from the Learning With Errors (LWE) [Reg05] and (exponentially hard) Learning Parity with Noise (LPN) problem [YZ16].

Our overall construction of IBE from hash encryption proceeds as follows. We first show that we can use any CPA PKE to build a *non-compact* version of One-Time Signatures with Encryption (OTSE), in which, informally, the size of the verification key of the OTSE is bigger than the size of the messages allowed to be signed. We then show how to use hash encryption to boost non-compact OTSE into compact OTSE, under which arbitrarily large messages could be signed using a short public parameter and a short verification key, while preserving the associated encryption-decryption functionalities. Our transformation makes a non-black-box use of the non-compact OTSE primitive.

Using a recent result by Döttling and Garg [DG], we transform our compact OTSE to an IBE. Hence, we obtain the first constructions of IBE from the LWE assumption used by Regev’s PKE and the first construction from an LPN problem.

Further, we show how to use non-compact OTSE to transform key-dependent-message (KDM) secure private key encryption to KDM-secure PKE. Informally, a private-key encryption scheme is  $\mathcal{F}$ -KDM secure, for a function class  $\mathcal{F}$ , if the scheme remains semantically secure even if the adversary is allowed to obtain encryptions of  $f(k)$ , for  $f \in \mathcal{F}$ , under  $k$  itself. This notion is analogously defined for PKE. A large body of work, e.g., [BHHO08, BG10, ACPS09, BHHI10, App14], shows how to build KDM-secure schemes from various specific assumptions. Briefly, in order to construct KDM-secure schemes for a large class of functions, they first show how to build KDM-secure schemes for a basic class of functions [BHHO08, BG10, ACPS09] (e.g., *projections*, *affine*) and then use KDM amplification procedures [BHHI10, App14] to obtain KDM security against richer functions families. We show that for any function family  $\mathcal{F}$ , an  $\mathcal{F}$ -KDM secure PKE can be obtained from a non-compact OTSE (and hence a CPA PKE) together with a  $\mathcal{G}$ -KDM secure private-key encryption scheme, where  $\mathcal{G}$  is a class of functions related to  $\mathcal{F}$ . (See Section 6 for a

formal statement.) Using the result of [App14] we obtain that  $\mathcal{F}$ -KDM-secure PKE, for any  $\mathcal{F}$ , can be based on projection-secure private-key encryption and CPA PKE. We mention that prior to our work it was not known whether projection-secure PKE (which is sufficient for KDM PKE) could be constructed (in a black-box or a non-black-box way) from the combination of CPA PKE and projection-secure private-key encryption.

An overview of the contributions of this work is given in Figure 1

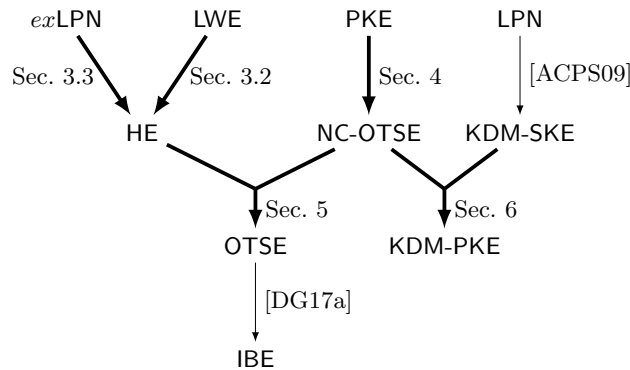

Fig. 1: Overview of the results in this work, bold arrows are contributions of this work.

### 1.3 Technical Outline

We will start by providing an outline of our construction of hash encryption from LWE. The LPN-based construction is similar in spirit, yet needs to account for additional subtleties that arise in the modulus 2 case. We will then sketch our construction of IBE from hash encryption.

*Hash Encryption from LWE* The hashing key  $k$  of our hash function is given by a randomly chosen matrix  $A \leftarrow \mathbb{Z}_p^{m \times \kappa}$ . To hash a message, we encoded it as a vector  $x \in \{0, 1\}^m \subseteq \mathbb{Z}^m$  and compute the hash value  $h \leftarrow x^\top \cdot A$ . It can be shown that under the short integer solution (SIS) problem [Reg05] this function is collision resistant.

We will now specify the encryption and decryption procedures. Our encryption scheme is a variant of the dual-Regev [GPV08] encryption scheme. For a matrix  $A$ , let  $A_{-i}$  denote the matrix obtained by removing the  $i$ -th row of  $A$ , and let  $a_i$  be the  $i$ -th row of  $A$ . Likewise, for a vector  $x$  let  $x_{-i}$  denote the vector obtained by dropping the  $i$ -th component of

x. Given the hashing key  $k = A$ , a hash-value  $h$ , an index  $i$  and a bit  $b$ , we encrypt a message  $m \in \{0, 1\}$  to a ciphertext  $c = (c_1, c_2)$  via

$$\begin{aligned} c_1 &\leftarrow A_{-i} \cdot s + e_{-i} \\ c_2 &\leftarrow (h - b \cdot a_i)s + e_i + \lfloor p/2 \rfloor \cdot m, \end{aligned}$$

where  $s \leftarrow \mathbb{Z}_p^k$  is chosen uniformly at random and  $e \in \mathbb{Z}_p^m$  is chosen from an appropriate discrete gaussian distribution.

To decrypt a ciphertext  $c$  using a preimage  $x$ , compute

$$\mu \leftarrow c_2 - x_{-i}^T c_1,$$

output 0 if  $\mu$  is closer to 0 and 1 if  $\mu$  is closer to  $p/2$ . Correctness of this scheme follows similarly as in the dual Regev scheme [GPV08]. To argue security, we will show that a successful adversary against this scheme can be used to break the decisional extended LWE problem [AP12], which is known to be equivalent to standard LWE.

*Compact OTSE from Non-Compact OTSE and Hash Encryption* To obtain a compact OTSE scheme, we hash the verification keys of the non-compact OTSE-scheme using the hash function of the hash encryption primitive. While this resolves the compactness issue, it destroys the encryption-decryption functionalities of the non-compact OTSE. We overcome this problem through a non-blackbox usage of the encryption function of the base non-compact OTSE-scheme.

*KDM Security* We sketch the construction of a  $\text{KDM}^{\text{CPA}}$ -secure PKE from a non-compact OTSE NC and a  $\text{KDM}^{\text{CPA}}$ -secure secret-key encryption scheme  $\text{SKE} = (\text{Enc}, \text{Dec})$ . We also need a garbling scheme  $(\text{Garble}, \text{Eval})$ , which can be built from SKE.

The public key  $\text{pk} = (\text{pp}, \text{vk})$  of the PKE is a public parameter  $\text{pp}$  and a verification key  $\text{vk}$  of NC and the secret key is  $\text{sk} = (k, \sigma)$ , where  $k$  is a key of the secret-key scheme and  $\sigma$  is a valid signature of  $k$  w.r.t.  $\text{vk}$ .

To encrypt  $m$  under  $\text{pk} = (\text{pp}, \text{vk})$  we first form a circuit  $C$  which on input  $k'$  returns  $\text{Enc}(k', m)$ . We then garble  $C$  to obtain a garbled circuit  $\tilde{C}$  and garbled inputs  $(X_{\iota,0}, X_{\iota,1})$  for every input index  $\iota$ . For all  $\iota$  and bit  $b$ , we OTSE-encrypt  $X_{\iota,b}$  relative to the index  $\iota$  and bit  $b$  (using  $\text{pp}$  and  $\text{vk}$ ) to get  $\text{ct}_{\iota,b}$ . The resulting ciphertext is then  $\text{ct} = (C, \{\tilde{\text{ct}}_{\iota,b}\}_{\iota,b})$ .

For decryption, using  $(k, \sigma)$  we can OTSE-decrypt the proper  $\text{ct}_{\iota,b}$ 's to obtain a matching garbled input  $\tilde{k}$  for  $k$ . Then using the garble evaluation mechanism we can obtain  $\text{ct}' = \text{Enc}(k, m)$ . We can then decrypt  $\text{ct}'$  using  $k$  to get  $m$  back.

Using a series of hybrids we reduce the KDM security of the PKE to the stated security properties of the base primitives.

## 2 Preliminaries

We use  $\{0,1\}_k^m$  to denote the set of binary vectors of length  $m$  with hamming weight  $k$  and  $[m]$  to denote the set  $\{1, \dots, m\}$ . We use  $A_{-i}$  to denote matrix  $A$  where the  $i$ th row is removed. The same holds for a row vector  $x_{-i}$ , which denotes vector  $x$  where the  $i$ th entry is removed.

**Lemma 1.** *For  $m \in \mathbb{N}$  and  $1 \leq k \leq m$ , the cardinality of set  $\{0,1\}_k^m$  is lower bounded by  $\binom{m}{k}^k$  and upper bounded by  $\left(\frac{em}{k}\right)^k$ .*

**Definition 1 (Bias).** *Let  $x \in \mathbb{F}_2$  be a random variable. Then the bias of  $x$  is defined by*

$$\text{bias}(x) = \Pr[x = 0] - \Pr[x = 1].$$

*Remark 1.* The bias of  $x$  is simply the second Fourier coefficient of the probability distribution of  $x$ , the first Fourier coefficient being 1 for all distributions. Thus, as  $\Pr[x = 1] = 1 - \Pr[x = 0]$  it holds that  $\Pr[x = 0] = \frac{1}{2} + \frac{1}{2}\text{bias}(x)$ .

In the following, we summarize several useful properties of the bias of random variables.

- If  $x \leftarrow B_\rho$ , then  $\text{bias}(x) = 1 - 2\rho$ .
- Let  $x_1, x_2 \in \mathbb{F}_2$  be independent random variables. Then it holds that  $\text{bias}(x_1 + x_2) = \text{bias}(x_1) \cdot \text{bias}(x_2)$ .
- Assume that the distribution of  $x$  is the convex combination of two distributions via  $p_x = \alpha p_{x_1} + (1 - \alpha)p_{x_2}$ . Then  $\text{bias}(x) = \alpha \text{bias}(x_1) + (1 - \alpha)\text{bias}(x_2)$ .

*Proof.* Convolution theorem

**Lemma 2.** *Let  $v \in \mathbb{F}_2^n$  be a vector of weight  $t$  and  $e \in \mathbb{F}_2^n$  a distribution for which each component is iid distributed with bias  $\epsilon$ . Then it holds that  $\Pr[\langle v, e \rangle = 0] = \frac{1}{2} + \frac{1}{2}\epsilon^t$ .*

*Proof.* As  $v$  has weight  $t$ , it holds that

$$\text{bias}(\langle v, e \rangle) = \text{bias}\left(\sum_{i=1, \dots, n; v_i=1} e_i\right) = \epsilon^t,$$

where the second equality follows by the properties of the bias. Consequently, it holds that  $\Pr[\langle v, e \rangle = 0] = \frac{1}{2} + \frac{1}{2}\epsilon^t$ .  $\square$

## 2.1 Hard Learning Problems.

We consider variants of the hard learning problems LWE and LPN that are known to be as hard. These variants are called extended LWE or LPN, since they leak some additional information about the noise term.

**Definition 2 (Extended LWE).** *An ppt algorithm  $\mathcal{A} = (\mathcal{A}_1, \mathcal{A}_2)$  breaks extended LWE for noise distribution  $\Psi$ ,  $m$  samples, modulus  $p$  and dimension  $\kappa$  if*

$$|\Pr[\mathcal{A}_2(\text{st}, A, As + e, x, x^T e) = 1] - \Pr[\mathcal{A}_2(\text{st}, A, B, x, x^T e) = 1]| \geq \text{negl},$$

where  $(x, \text{st}) \leftarrow \mathcal{A}_1(1^\kappa)$  and the randomness is taken over  $A \leftarrow \mathbb{Z}_p^{m \times \kappa}$ ,  $B \leftarrow \mathbb{Z}_p^m$ ,  $s \leftarrow \mathbb{Z}_p^\kappa$ , and  $e \leftarrow \Psi$ .

**Lemma 3 ([AP12, Theorem 3.1]).** *For dimension  $n$ , modulus  $q$  with smallest prime divisor  $p$ ,  $m \geq n + \omega(\log(n))$  samples and noise distribution  $\Psi$ , if there is an algorithm solving extended LWE with probability  $\epsilon$ , then there is an algorithm solving LWE with probability  $\frac{\epsilon}{2p-1}$  as long as  $p$  is an upper bound on the norm of the hint  $x^T e$ .*

When  $p = 2$  and the noise distribution  $\Psi = B_\rho$  is the Bernoulli distribution, we call the problem LPN. For the LPN based encryption scheme, we need to embed a sufficiently strong binary error correction code such that decryption can recover a message. Therefore, we define a hybrid version of extended LPN that is able to hide a sufficiently large generator matrix of such a code.

**Definition 3 (Extended Hybrid LPN).** *An ppt algorithm  $\mathcal{A} = (\mathcal{A}_1, \mathcal{A}_2)$  breaks extended LPN for noise distribution  $B_\rho$ ,  $m$  samples, modulus  $p$ , dimension  $\kappa$  and  $\ell$  hybrids if*

$$|\Pr[\mathcal{A}_2(\text{st}, A, AS + E, x, x^T E) = 1] - \Pr[\mathcal{A}_2(\text{st}, A, B, x, x^T E) = 1]| \geq \text{negl},$$

where  $(x, \text{st}) \leftarrow \mathcal{A}_1(1^n)$  and the randomness is taken over  $A \leftarrow \mathbb{Z}_p^{m \times \kappa}$ ,  $B \leftarrow \mathbb{Z}_p^{m \times \ell}$ ,  $S \leftarrow \mathbb{Z}_p^{\kappa \times \ell}$ , and  $E \leftarrow B_\rho^{m \times \ell}$ .

A simple hybrid arguments yields that if extended hybrid LPN can be broken with probability  $\epsilon$ , then extended LPN can be broken with probability  $\epsilon/\ell$ . Therefore we consider extended hybrid LPN as as hard as extended LPN.



## 2.2 Weak Commitments.

In our LPN-based hash encryption scheme, we will use a list decoding procedure to receive a list of candidate messages during the decryption of a ciphertext. To determine which candidate message has been encrypted, we add a weak form of a commitment of the message to the ciphertext that hides the message. In order to derive the correct message from the list of candidates, we require that the commitment is binding with respect to the list of candidates, i.e. the list decoding algorithm.

**Definition 4 (Weak Commitment for List Decoding).** *A weak commitment scheme with respect to a list decoding algorithm  $D$  ( $WC_D$ ) consists of three ppt algorithms  $\text{Gen}$ ,  $\text{Commit}$ , and  $\text{Verify}$ , a message space  $M \subset \{0, 1\}^*$  and a randomness space  $R \subset \{0, 1\}^*$ .*

- $\text{Gen}(1^\kappa)$ : Outputs a key  $k$ .
- $\text{Commit}(k, m, r)$ : Outputs a commitment  $wC(m, r)$ .
- $\text{Verify}(k, m, r, wC)$ : Outputs 1 if and only if  $wC(m, r) = wC$ .

For hiding, we require that for any ppt algorithm  $\mathcal{A} = (\mathcal{A}_1, \mathcal{A}_2)$

$$|\Pr[\mathcal{A}_2(\text{st}, wC(m_0, r)) = 1] - \Pr[\mathcal{A}_2(\text{st}, wC(m_1, r)) = 1]| \leq \text{negl},$$

where  $(m_0, m_1, \text{st}) \leftarrow \mathcal{A}_1(k)$  and the randomness is taken over the random coins of  $\mathcal{A}$ ,  $k \leftarrow \text{Gen}(1^\kappa)$  and  $r \leftarrow R$ . For binding with respect to  $D$ , we require that for any  $m \in M$

$$\Pr[\text{Verify}(k, m, r, wC(m', r')) = 1 \wedge m \neq m'] \leq \text{negl},$$

where the randomness is taken over  $(m', r') \leftarrow D(1^n, m, r)$ , the random coins of  $\text{Verify}$ ,  $D$ ,  $k \leftarrow \text{Gen}(1^\kappa)$  and  $r \leftarrow R$ .

Since  $D$  does not depend on hash key  $k$ , a  $wC_D$  can be easily instantiated with a universal hash function. Key  $k$  corresponds to the hash function  $h$  and  $wC(m, r) := h(m, r)$  is the hash of  $m$  and  $r$ . In the following we define universal hash functions and show with two lemmata that our construction of a weak commitment is hiding as well as binding.

**Definition 5.** *For  $n, m \in \mathbb{N}$ ,  $m > n$ , a family of functions  $H$  from  $\{0, 1\}^m$  to  $\{0, 1\}^n$  is called a family of universal hash functions if for any  $x, x' \in \{0, 1\}^m$  with  $x \neq x'$*

$$\Pr_{h \leftarrow H}[h(x) = h(x')] \leq 2^{-n}.$$

**Lemma 4.**  $h$  is weakly binding with respect to  $D$ . In particular,

$$\Pr_{h \leftarrow H}[\exists i \in [\ell] : h(m, r) = h(m_i, r_i) \wedge m \neq m_i] \leq \ell 2^{-n},$$

where  $\{(m_i, r_i)\}_{i \in [\ell]} \leftarrow D(1^n, m, r)$  and  $\ell$  is the output list length of  $D$ .

*Proof.*  $D$  outputs a list of at most  $\ell$  tuples of the form  $(m_1, r_1), \dots, (m_\ell, r_\ell)$ . For each of the tuples with  $m_i \neq m$ ,

$$\Pr_{h \leftarrow H}[h(m, r) = h(m_i, r_i)] \leq 2^{-n}$$

holds. Using a union bound, we receive the statement of the lemma.

The work of Hastad et. al. [HILL99] shows that for an  $r$  with sufficient entropy, for any  $m$ ,  $h(r, m)$  is statistical close to uniform. Therefore it statistically hides the message  $m$ .

**Lemma 5 ([HILL99] Lemma 4.5.1).** *Let  $h$  be a universal hash function from  $\{0, 1\}^m$  to  $\{0, 1\}^n$  and  $r \leftarrow \{0, 1\}^{|r|}$  for  $|r| \geq 2\kappa + n$ , then for any  $m$ ,  $h(r, m)$  is statistically close to uniform given  $h$ .*

### 2.3 Secret- and Public-Key Encryption

We will briefly review the security notions for secret- and public-key encryption this work is concerned with.

**Definition 6.** *A secret-key encryption scheme SKE consists of two algorithms Enc and Dec with the following syntax*

- $\text{Enc}(k, m)$ : Takes as input a key  $k \in \{0, 1\}^\kappa$  and a message  $m \in \{0, 1\}^\ell$  and outputs a ciphertext  $c$ .
- $\text{Dec}(k, ct)$ : Takes as input a key  $k \in \{0, 1\}^\kappa$  and a ciphertext  $ct$  and outputs a message  $m$ .

For correctness, for all  $k \in \{0, 1\}^\kappa$  and  $m \in \{0, 1\}^\ell$  we have :

$$\text{Dec}(k, \text{Enc}(k, m)) = m.$$

The standard security notion of secret-key encryption is indistinguishability under chosen plaintext attacks (IND-CPA). However, the notion of interest in this work is the stronger notion of key-dependent-message security under chosen-plaintext attacks. A secret-key encryption scheme

SKE = (Enc, Dec) is called key-dependent-message secure under chosen plaintext attacks ( $\text{KDM}^{\text{CPA}}$ ) if for every PPT-adversary  $\mathcal{A}$  the advantage

$$\text{Adv}_{\text{KDM}^{\text{CPA}}}(\mathcal{A}) = \left| \Pr[\text{KDM}^{\text{CPA}}(\mathcal{A}) = 1] - \frac{1}{2} \right|$$

is at most negligible advantage in the following experiment:

**Experiment**  $\text{KDM}^{\text{CPA}}(\mathcal{A})$ :

1.  $k \xleftarrow{\$} \{0, 1\}^\kappa$
2.  $b^* \xleftarrow{\$} \{0, 1\}$
3.  $b' \leftarrow \mathcal{A}^{\text{KDM}_{b^*, k}(\cdot)}(1^\kappa)$   
 where the oracle  $\text{KDM}$  is defined by  $\text{KDM}_{0, k}(f) = \text{PKE.Enc}(k, f(k))$  and  $\text{KDM}_{1, k}(f) = \text{PKE.Enc}(k, 0^\ell)$ .
4. Output 1 if  $b' = b^*$  and 0 otherwise.

Fig. 2: The  $\text{IND}^{\text{OTSIG}}(\mathcal{A})$  Experiment

**Definition 7.** A public-key encryption scheme PKE consists of three (randomized) algorithms KeyGen, Enc and Dec with the following syntax.

- $\text{KeyGen}(1^\kappa)$ : Takes as input the security parameter  $1^\kappa$  and outputs a pair of public and secret keys  $(\text{pk}, \text{sk})$ .
- $\text{Enc}(\text{pk}, m)$ : Takes as input a public key  $\text{pk}$  and a message  $m \in \{0, 1\}^\ell$  and outputs a ciphertext  $c$ .
- $\text{Dec}(\text{sk}, c)$ : Takes as input a secret key  $\text{sk}$  and a ciphertext  $c$  and outputs a message  $m$ .

In terms of correctness, we require that for all messages  $m \in \{0, 1\}^\ell$  and  $(\text{pk}, \text{sk}) \leftarrow \text{KeyGen}(1^\kappa)$  that

$$\text{Dec}(\text{sk}, \text{Enc}(\text{pk}, m)) = m.$$

A public-key encryption scheme  $\text{PKE} = (\text{KeyGen}, \text{Enc}, \text{Dec})$  is called  $\text{IND}^{\text{CPA}}$ -secure, if for every PPT-adversary  $\mathcal{A}$  the advantage

$$\text{Adv}_{\text{IND}^{\text{CPA}}}(\mathcal{A}) = \left| \Pr[\text{IND}^{\text{CPA}}(\mathcal{A}) = 1] - \frac{1}{2} \right|$$

is at most negligible in the following experiment:

**Experiment**  $\text{KDM}^{\text{CPA}}(\mathcal{A})$ :

1.  $(\text{pk}, \text{sk}) \leftarrow \text{PKE.KeyGen}(1^\kappa)$
2.  $(\text{m}_0, \text{m}_1) \leftarrow \mathcal{A}_1(\text{pk})$
3.  $b^* \xleftarrow{\$} \{0, 1\}$
4.  $\text{c}^* \leftarrow \text{PKE.Enc}(\text{pk}, \text{m}_b)$
5.  $b' \leftarrow \mathcal{A}_2(\text{pk}, \text{c}^*)$
6. Output 1 if  $b' = b^*$  and 0 otherwise.

Fig. 3: The  $\text{IND}^{\text{CPA}}(\mathcal{A})$  Experiment

A public-key encryption scheme  $\text{PKE} = (\text{KeyGen}, \text{Enc}, \text{Dec})$  is called *key-dependent-message secure under chosen plaintext attacks* ( $\text{KDM}^{\text{CPA}}$ ), if for every PPT-adversary  $\mathcal{A}$  the advantage

$$\text{Adv}_{\text{KDM}^{\text{CPA}}}(\mathcal{A}) = \left| \Pr[\text{KDM}^{\text{CPA}}(\mathcal{A}) = 1] - \frac{1}{2} \right|$$

is at most negligible in the following experiment:

**Experiment**  $\text{KDM}^{\text{CPA}}(\mathcal{A})$ :

1.  $(\text{pk}, \text{sk}) \leftarrow \text{PKE.KeyGen}(1^\kappa)$
2.  $b^* \xleftarrow{\$} \{0, 1\}$
3.  $b' \leftarrow \mathcal{A}^{\text{KDM}_{b^*, \text{sk}(\cdot)}}(\text{pk})$   
 where the oracle  $\text{KDM}$  is defined by  $\text{KDM}_{0, \text{sk}}(f) = \text{PKE.Enc}(\text{pk}, f(\text{sk}))$  and  $\text{KDM}_{1, \text{sk}}(f) = \text{PKE.Enc}(\text{pk}, 0^\ell)$ .
4. Output 1 if  $b' = b^*$  and 0 otherwise.

Fig. 4: The  $\text{IND}^{\text{CPA}}(\mathcal{A})$  Experiment

## 2.4 One-Time Signatures with Encryption [DG17a]

**Definition 8.** A *One-Time Signature Scheme with Encryption* consists of five algorithms ( $\text{SSetup}, \text{SGen}, \text{SSign}, \text{SEnc}, \text{SDec}$ ) defined as follows:

- $\text{SSetup}(1^\kappa)$ : Takes as input a unary encoding of the security parameter  $1^\kappa$  and outputs public parameters  $\text{pp}$ .

- $\text{SGen}(\text{pp}, \ell)$ : Takes as input public parameters  $\text{pp}$  and a message length parameter  $\ell$  and outputs a pair  $(\text{vk}, \text{sk})$  of verification and signing keys.
- $\text{SSign}(\text{sk}, x)$ : Takes as input a signing key  $\text{sk}$  and a message  $x \in \{0, 1\}^\ell$  and outputs a signature  $\sigma$ .
- $\text{SEnc}(\text{pp}, (\text{vk}, i, b), \text{m})$ : Takes as input public parameters  $\text{pp}$ , a verification key  $\text{vk}$ , an index  $i$ , a bit  $b$  and a plaintext  $\text{m}$  and outputs a ciphertext  $\text{c}$ . We will generally assume that the index  $i$  and the bit  $b$  are included alongside
- $\text{SDec}(\text{pp}, (\text{vk}, \sigma, x), \text{c})$ : Takes as input public parameters  $\text{pp}$ , a verification key  $\text{vk}$ , a signature  $\sigma$ , a message  $x$  and a ciphertext  $\text{c}$  and returns a plaintext  $\text{m}$ .

We require the following properties.

- **Compactness**: For  $(\text{vk}, \text{sk}) \leftarrow \text{SGen}(\text{pp}, \ell)$  it holds that  $|\text{vk}| < \ell$ , i.e.  $\text{vk}$  can be described with less than  $\ell$  bits.
- **Correctness**: For all security parameters  $\kappa$ , message  $x \in \{0, 1\}^\ell$ ,  $i \in [\ell]$ ,  $b \in \{0, 1\}$  and plaintext  $\text{m}$ : if  $\text{pp} \leftarrow \text{Setup}(1^\kappa)$ ,  $(\text{vk}, \text{sk}) \leftarrow \text{SGen}(\text{pp}, \ell)$  and  $\sigma \leftarrow \text{SSign}(\text{sk}, x)$  then

$$\text{SDec}(\text{pp}, (\text{vk}, \sigma, x), \text{SEnc}(\text{pp}, (\text{vk}, i, b), \text{m})) = \text{m}.$$

- **Selective Security**: For any PPT adversary  $\mathcal{A} = (\mathcal{A}_1, \mathcal{A}_2, \mathcal{A}_3)$ , there exists a negligible function  $\text{negl}(\cdot)$  such that the following holds:

$$\Pr[\text{IND}^{\text{OTSIG}}(\mathcal{A}) = 1] \leq \frac{1}{2} + \text{negl}(\kappa)$$

where  $\text{IND}^{\text{IBE}}(\mathcal{A})$  is shown in Figure 5.

**Experiment**  $\text{IND}^{\text{OTSIG}}(\mathcal{A})$ :

1.  $\text{pp} \leftarrow \text{SSetup}(1^\kappa)$
2.  $(\text{vk}, \text{sk}) \leftarrow \text{SGen}(\text{pp}, \ell)$
3.  $x \leftarrow \mathcal{A}_1(\text{pp}, \text{vk})$
4.  $\sigma \leftarrow \text{SSign}(\text{sk}, x)$
5.  $(i, \text{m}_0, \text{m}_1) \leftarrow \mathcal{A}_2(\text{pp}, \text{vk}, \sigma)$
6.  $b^* \xleftarrow{\$} \{0, 1\}$
7.  $\text{m}^* \leftarrow \text{m}_{b^*}$
8.  $\text{c}^* \leftarrow \text{SEnc}(\text{pp}, (\text{vk}, i, 1 - x_i), \text{m}^*)$
9.  $b' \leftarrow \mathcal{A}_3(\text{pp}, \text{vk}, \sigma, \text{c}^*)$
10. Output 1 if  $b' = b^*$  and 0 otherwise.

Fig. 5: The  $\text{IND}^{\text{OTSIG}}(\mathcal{A})$  Experiment

We remark that multi-challenge security follows via a simple hybrid argument. We also remark that in the definition of [DG17a], the message  $x$  was not allowed to depend on  $\text{vk}$ . The definition given here is stronger and readily implies the definition of [DG17a].

If an OTSE scheme does not fulfill the compactness property, then we refer to such a scheme as a non-compact OTSE-scheme or NC-OTSE.

Döttling and Garg [DG17a] showed that (compact) OTSE implies both fully secure IBE and selectively secure HIBE.

**Theorem 2 (Informal).** *Assume there exists an OTSE-scheme. Then there exists a fully secure IBE-scheme and a HIBE-scheme.*

## 2.5 Garbled Circuits

Garbled circuits were first introduced by Yao [Yao82] (see Lindell and Pinkas [LP09] and Bellare et al. [BHR12] for a detailed proof and further discussion). A projective circuit garbling scheme is a tuple of PPT algorithms ( $\text{Garble}$ ,  $\text{Eval}$ ) with the following syntax.

- $\text{Garble}(1^\kappa, C)$  takes as input a security parameter  $\kappa$  and a circuit  $C$  and outputs a *garbled circuit*  $\tilde{C}$  and labels  $e_C = \{X_{\ell,0}, X_{\ell,1}\}_{\ell \in [n]}$ , where  $n$  is the number of input wires of  $C$ .
- Projective Encoding: To encode an  $x \in \{0, 1\}^n$  with the input labels  $e_C = \{X_{\ell,0}, X_{\ell,1}\}_{\ell \in [n]}$ , we compute  $\tilde{x} \leftarrow \{X_{\ell, x_\ell}\}_{\ell \in [n]}$ .
- $\text{Eval}(\tilde{C}, \tilde{x})$ : takes as input a garbled circuit  $\tilde{C}$  and a garbled input  $\tilde{x}$ , represented as a sequence of input labels  $\{X_{\ell, x_\ell}\}_{\ell \in [n]}$ , and outputs an output  $y$ .

We will denote hardwiring of an input  $s$  into a circuit  $C$  by  $C[s]$ . The garbling algorithm  $\text{Garble}$  treats the hardwired input as a regular input and additionally outputs the garbled input corresponding to  $s$  (instead of all the labels of the input wires corresponding to  $s$ ). If a circuit  $C$  uses additional randomness, we will implicitly assume that appropriate random coins are hardwired in this circuit during garbling.

*Correctness.* For correctness, we require that for any circuit  $C$  and input  $x \in \{0, 1\}^n$  we have that

$$\Pr \left[ C(x) = \text{Eval}(\tilde{C}, \tilde{x}) \right] = 1$$

where  $(\tilde{C}, e_C = \{X_{\ell,0}, X_{\ell,1}\}_{\ell \in [n]}) \stackrel{\$}{\leftarrow} \text{Garble}(1^\kappa, C)$  and  $\tilde{x} \leftarrow \{X_{\ell, x_\ell}\}$ .

*Security.* For security, we require that there is a PPT simulator  $\text{GCSim}$  such that for any circuit  $C$  and any input  $x$ , we have that

$$(\tilde{C}, \tilde{x}) \approx_c \text{GCSim}(C, C(x))$$

where  $(\tilde{C}, e_C = \{X_{\ell,0}, X_{\ell,1}\}_{\ell \in [n]}) \leftarrow \text{Garble}(1^\kappa, C)$  and  $\tilde{x} \leftarrow \{X_{\ell, x_\ell}\}$ .

### 3 Hash Encryption from Learning Problems

Intuitively, our hash encryption scheme can be seen as a witness encryption scheme that uses a hash value and a key to encrypt a message. The decryption procedure requires the knowledge of a preimage of the hash value to recover an encrypted message. Given key  $k$ , an algorithm  $\text{Hash}$  allows to compute a hash value for an input  $x$ . This hashing procedure is tied to the hash encryption scheme. More concretely, the encryption procedure encrypts a message with respect to a bit  $c$  for an index  $i$ . Given knowledge of a preimage, where the  $i$ th bit has value  $c$ , one can successfully decrypt the initially encrypted message. Due to this additional constraint, a hash encryption is more restrictive than a witness encryption for the knowledge of the preimage of a hash value.

#### 3.1 Hash Encryption

**Definition 9 (Hash Encryption).** *A hash encryption (HE) consists of four ppt algorithms  $\text{Gen}$ ,  $\text{Hash}$ ,  $\text{Enc}$  and  $\text{Dec}$  with the following syntax*

- $\text{Gen}(1^\kappa, m)$ : *Takes as input the security parameter  $\kappa$ , an input length  $m$  and outputs a key  $k$ .*
- $\text{Hash}(k, x)$ : *Takes a key  $k$ , an input  $x \in \{0, 1\}^m$  and outputs a hash value  $h$  of  $\kappa$  bits.*
- $\text{Enc}(k, (h, i, c), m)$ : *Takes a key  $k$ , a hash value  $h$  an index  $i \in [m]$ ,  $c \in \{0, 1\}$  and a message  $m \in \{0, 1\}^*$  as input and outputs a ciphertext  $\text{ct}$ .*
- $\text{Dec}(k, x, \text{ct})$ : *Takes a key  $k$ , an input  $x$  and a ciphertext  $\text{ct}$  as input and outputs a value  $m \in \{0, 1\}^*$  (or  $\perp$ ).*

*Correctness.* For correctness, we require that for any input  $x \in \{0, 1\}^m$ , index  $i \in [m]$

$$\Pr[\text{Dec}(k, x, \text{Enc}(k, (\text{Hash}(k, x), i, x_i), m)) = m] \geq 1 - \text{negl},$$

where  $x_i$  denotes the  $i$ th bit of  $x$  and the randomness is taken over  $k \leftarrow \text{Gen}(1^\kappa, m)$ .

*Security.* We call a HE secure, i.e. selectively indistinguishable, if for any ppt algorithm  $\mathcal{A}$

$$\Pr[\text{IND}^{\text{HE}}(1^\kappa, \mathcal{A}) = 1] \leq \frac{1}{2} + \text{negl},$$

where the game  $\text{IND}^{\text{HE}}$  is defined in Figure 6.

**Experiment  $\text{IND}^{\text{HE}}(\mathcal{A})$ :**

1.  $(x, \text{st}_1) \leftarrow \mathcal{A}_1(1^\kappa)$
2.  $k \leftarrow \text{Gen}(1^\kappa, m)$
3.  $(i \in [m], m_0, m_1, \text{st}_2) \leftarrow \mathcal{A}_2(\text{st}_1, k)$
4.  $b \leftarrow \{0, 1\}$
5.  $\text{ct} \leftarrow \text{Enc}(k, (\text{Hash}(k, x), i, 1 - x_i), m_b)$
6.  $b' \leftarrow \mathcal{A}_3(\text{st}_2, \text{ct})$
7. Output 1 if  $b' = b$  and 0 otherwise.

Fig. 6: The  $\text{IND}^{\text{HE}}(\mathcal{A})$  Experiment

### 3.2 Hash Encryption from LWE

We use the same parameters as proposed by the PKE of [Reg05], i.e. Gaussian noise distribution  $\Psi_{\alpha(\kappa)}$  for  $\alpha(\kappa) = o\left(\frac{1}{\sqrt{\kappa \log(\kappa)}}\right)$ , prime modulus  $\kappa^2 \leq p \leq 2\kappa^2$ ,  $m = (1 + \epsilon)(1 + \kappa) \log(\kappa)$  for  $\epsilon > 0$ . For hash domain  $\{0, 1\}^m$  and message space  $M = \{0, 1\}$ , we define our LWE based HE as follows.

- $\text{Gen}(1^\kappa, m)$ : Sample  $A \leftarrow \mathbb{Z}_p^{m \times \kappa}$ .
- $\text{Hash}(k, x)$ : Output  $x^T A$ .
- $\text{Enc}(k, (h, i, c), m)$ : Sample  $s \leftarrow \mathbb{Z}_p^\kappa$ ,  $e \leftarrow \Psi_{\alpha(\kappa)}^m$  and compute

$$\begin{aligned} c_1 &:= A_{-i} s + e_{-i} \\ c_2 &:= (h - c \cdot a_i) s + e_i + \lfloor p/2 \rfloor \cdot m. \end{aligned}$$

Output  $\text{ct} = (c_1, c_2)$ .

- $\text{Dec}(k, x, \text{ct})$ : Output 1 if  $c_2 - x_{-i}^T c_1$  is closer to  $p/2$  than to 0 and otherwise output 0.

Depending on the concrete choice of  $m = (1 + \epsilon)(1 + \kappa) \log(\kappa)$ , the compression factor of the hash function is determined. For our purposes, the construction of an IBE, any choice of  $\epsilon > 0$  is sufficient.



**Lemma 6.** *For the proposed parameters, the LWE based HE is correct.*

*Proof.*  $\text{ct} = (c_1, c_2)$  is an output of  $\text{Enc}(k, (h, i, c), m)$ , then for any  $x$  with  $\text{Hash}(k, x) = h$ ,  $c_2$  has the form

$$c_2 = (x^T A - c \cdot a_i)s + e_i + \lfloor p/2 \rfloor \cdot m.$$

Therefore, on input  $x$ ,  $c = x_i$ , Dec computes

$$\begin{aligned} c_2 - x_{-i}^T c_1 &= (x^T A - c \cdot a_i)s + e_i + \lfloor p/2 \rfloor \cdot m - x_{-i}^T A_{-i}s - x_{-i}^T e_{-i} \\ &= (x_i - c) \cdot a_i s + e_i + \lfloor p/2 \rfloor \cdot m - x_{-i}^T e_{-i} \\ &= \lfloor p/2 \rfloor \cdot m + e_i - x_{-i}^T e_{-i}. \end{aligned}$$

By [Reg05, Claim 5.2], for any  $x \in \{0, 1\}^m$ ,  $|e_i - x_{-i}^T e_{-i}| < p/4$  holds with overwhelming probability. Hence, the noise is sufficiently small such that Dec outputs  $m$ .

**Theorem 3.** *The LWE based HE is  $\text{IND}^{\text{HE}}$  secure under the extended LWE assumption for dimension  $\kappa$ , Gaussian noise parameter  $\alpha(n) = o(\frac{1}{\sqrt{n \log(n)}})$ , prime modulus  $\kappa^2 \leq p \leq 2\kappa^2$ , and  $m = (1 + \epsilon)(1 + \kappa) \log(n)$  samples.*

*Proof.* Let  $\mathcal{A}$  be an adversary that successfully breaks the  $\text{IND}^{\text{HE}}$  security of the proposed HE. Then there is an algorithm  $\mathcal{A}'$  that breaks the extended LWE assumption with the same probability.

We construct  $\mathcal{A}' = (\mathcal{A}'_1, \mathcal{A}'_2)$  as follows:

$\mathcal{A}'_1(1^\kappa, \mathcal{A}_1):$	$\mathcal{A}'_2(\text{st}', \mathcal{A}_2, \mathcal{A}_3, A, B, x^T e):$
$(x, \text{st}_1) \leftarrow \mathcal{A}_1(1^\kappa)$	$k := A$
$\text{st}' := (x, \text{st}_1)$	$(i \in [m], m_0, m_1, \text{st}_2) \leftarrow \mathcal{A}_2(\text{st}_1, k)$
Return $x$	$b \leftarrow \{0, 1\}$
	$c_1 := B_{-i}$
	$c_2 := B_i + \lfloor p/2 \rfloor \cdot m_b - x_{-i}^T e_{-i} + x_{-i}^T c_1$
	$b' \leftarrow \mathcal{A}_3(\text{st}_2, \text{ct} = (c_1, c_2))$
	Return $b = b'$

In the LWE case,  $B = As + e$ . Therefore  $\mathcal{A}'$  creates  $\text{ct}$  with the same distribution as in game  $\text{IND}^{\text{HE}}$ . This is easy to see for  $c_1 = B_{-i} = A_{-i}s + e_{-i}$ . For  $c_2$ , we have

$$\begin{aligned} c_2 &= B_i + \lfloor p/2 \rfloor \cdot m_b - x_{-i}^T e_{-i} + x_{-i}^T c_1 \\ &= a_i s + e_i + \lfloor p/2 \rfloor \cdot m_b - x_{-i}^T e_{-i} + x_{-i}^T A_{-i}s + x_{-i}^T e_{-i} \\ &= a_i s + e_i + \lfloor p/2 \rfloor \cdot m_b + x_{-i}^T A_{-i}s \\ &= (h + (1 - x_i)a_i)s + e_i + \lfloor p/2 \rfloor \cdot m_b. \end{aligned}$$

In the uniform case,  $B$  is uniform and therefore  $\mathcal{A}$ 's guess  $b'$  is independent of  $b$ . Hence,  $\mathcal{A}'_2$  outputs 1 with probability  $\frac{1}{2}$ .  $\mathcal{A}'$  breaks extended LWE with probability

$$\begin{aligned} & \left| \Pr[\mathcal{A}_3(\text{st}', A, As + e, x, x^T e) = 1] - \Pr[\mathcal{A}_3(\text{st}', A, B, x, x^T e) = 1] \right| \\ &= \left| \Pr[\text{IND}^{\text{HE}}(\mathcal{A}) = 1] - \frac{1}{2} \right|. \end{aligned}$$

### 3.3 Hash Encryption from Exponentially Hard LPN

For LPN, we use a Bernoulli noise distribution  $B_\rho$  with Bernoulli parameter  $\rho = c_\rho$  and hash domain  $\mathbf{x} \in \{0, 1\}_k^m$ , where  $k = c_k \log(\kappa)$  for constants  $c_\rho$  and  $c_k$ .  $G \in \mathbb{Z}_2^{(|\mathbf{m}|+\kappa) \times \ell}$  is the generator matrix of a binary, list decodable error correction code that corrects an error with  $1/\text{poly}$  bias, where  $|\mathbf{m}|$  is the message length and  $\ell$  the dimension of the codewords. For this task, we can use the error correction code proposed by Guruswami and Rudra [GR11]. Further, we use a weak commitment scheme  $\text{WC}$  with respect to the list decoding algorithm of  $G$ .

- $\text{Gen}(1^\kappa, m)$ : Sample  $A \leftarrow \mathbb{Z}_2^{m \times \log^2(\kappa)}$ , output  $\mathbf{k} := A$ .
- $\text{Hash}(\mathbf{k}, \mathbf{x})$ : Output  $\mathbf{x}^T A$ .
- $\text{Enc}(\mathbf{k}, (\mathbf{h}, i, c), \mathbf{m})$ : Sample  $S \leftarrow \mathbb{Z}_2^{\log^2(\kappa) \times \ell}$ ,  $E \leftarrow B_\rho^{m \times \ell}$ , and a random string  $r \leftarrow \text{RWC}$  and compute

$$\begin{aligned} c_0 &:= \mathbf{k}_{\text{WC}} \leftarrow \text{Gen}_{\text{WC}}(1^\kappa) \\ c_1 &:= A_{-i} S + E_{-i} \\ c_2 &:= (\mathbf{h} - c \cdot a_i) S + E_i + (\mathbf{m} || r) \cdot G \\ c_3 &:= \text{wC}(\mathbf{m}, r) \leftarrow \text{Commit}(\mathbf{k}_{\text{WC}}, \mathbf{m}, r). \end{aligned}$$

Output  $\text{ct} = (c_1, c_2, c_3)$ .

- $\text{Dec}(\mathbf{k}, \mathbf{x}, \text{ct})$ : Use code  $G$  to list decode  $c_2 - \mathbf{x}_{-i}^T c_1$ . Obtain from the list of candidates the candidate  $(\mathbf{m} || r)$  that fits  $\text{Verify}(c_0, \mathbf{m}, r, c_3) = 1$ . Output this candidate.

The choice of constant  $c_k$  will determine the compression factor of the hash function  $\text{Hash}$ . The compression is determined by the ration between  $|\{0, 1\}_k^m|$  and the space of the LPN secret  $2^{\log^2(\kappa)}$ . By Lemma 1, the cardinality of  $|\{0, 1\}_k^m|$  is lower bounded by  $(\frac{m}{c_k \log(\kappa)})^{c_k \log(\kappa)}$ .  $m := c\kappa$  yields a compression factor of at least  $c_k(c - \frac{\log(c_k \log(\kappa))}{\log \kappa})$ , which allows any constant compression factor for a proper choice of the constants  $c$  and  $c_k$ .

For the correctness, we need to rely on the error correction capacity of code  $G$  and the binding property of the weak commitment scheme. For properly chosen constants  $c_\rho$  and  $k$ , the proposed HE is correct.

**Lemma 7.** *For  $\rho = c_\rho \leq \frac{1}{4}$ ,  $k = c_k \log(\kappa)$ , and an error correction code  $G$  that corrects an error with a bias of  $2^{-4c_\rho \kappa^{-4c_\rho c_k}}$  and let WC be a weak commitment that is binding with respect to the list decoding of  $G$ , then the LPN based HE is correct.*

*Proof.*  $\mathbf{ct} = (c_0, c_1, c_2, c_3)$  is an output of  $\text{Enc}(k, (h, i, c), \mathbf{m})$ , then for any  $\mathbf{x}$  with  $\text{Hash}(k, \mathbf{x}) = h$ ,  $c_2$  has the form

$$c_2 = (\mathbf{x}^T A - c \cdot a_i)S + E_i + (\mathbf{m}||\mathbf{r}) \cdot G.$$

Therefore, on input  $\mathbf{x}$ ,  $c = x_i$ , Dec computes

$$\begin{aligned} c_2 - \mathbf{x}_{-i}^T c_1 &= (\mathbf{x}^T A - c \cdot a_i)S + E_i + (\mathbf{m}||\mathbf{r}) \cdot G - \mathbf{x}_{-i}^T A_{-i} S - \mathbf{x}_{-i}^T E_{-i} \\ &= (x_i - c) \cdot a_i S + E_i + (\mathbf{m}||\mathbf{r}) \cdot G - \mathbf{x}_{-i}^T E_{-i} \\ &= (\mathbf{m}||\mathbf{r}) \cdot G + E_i - \mathbf{x}_{-i}^T E_{-i}. \end{aligned}$$

By Lemma 2, for each component  $e_j$ ,  $j \in [\ell]$  of  $e := E_i - \mathbf{x}_{-i}^T E_{-i}$  and  $\rho \leq \frac{1}{4}$ ,

$$\begin{aligned} \rho' := \Pr[e_j = 1] &= \frac{1}{2}(1 - (1 - 2\rho)^{k+1}) \leq \frac{1}{2} \left(1 - 2^{-4c_\rho(c_k \log(\kappa)+1)}\right) \\ &= \frac{1}{2} \left(1 - 2^{-4c_\rho \kappa^{-4c_\rho c_k}}\right). \end{aligned}$$

This lower bounds the bias of each component of the noise term  $E_i - \mathbf{x}_{-i}^T E_{-i}$  by bound  $2^{-4c_\rho \kappa^{-4c_\rho c_k}}$ . This bound is polynomial in  $\kappa$  and therefore correctable by a suitable error correction code with list decoding. Hence,  $(\mathbf{m}||\mathbf{r})$  is contained in the output list of candidates of the list decoding. By the binding of WC, there is with overwhelming probability only a single candidate of the polynomially many candidates that fits  $\text{Verify}(c_0, \mathbf{m}, \mathbf{r}, c_3) = 1$ , which corresponds to the initially encrypted message  $\mathbf{m}$ . Otherwise, the list decoding of  $G$  would break the binding property of WC.  $\square$

The security analysis is similar to the one of the LWE based scheme with the difference that now a ciphertext also contains a commitment which depends on the encrypted message. In a first step, we use the LPN assumption to argue that all parts of the ciphertext are computationally independent of the message. In a second step, we use the hiding property

of the commitment scheme to argue that now the whole ciphertext is independent of the encrypted message and therefore an adversary cannot break the scheme.

**Theorem 4.** *Let WC be a weak commitment scheme that is hiding, then the LPN based HE is  $\text{IND}^{\text{HE}}$  secure under the extended hybrid LPN assumption for dimension  $\log^2(\kappa)$ ,  $m$  samples,  $\ell$  hybrids and noise level  $\rho$ .*

*Proof.* In Figure 7, we define the games  $G_1$  and  $G_2$ , where  $G_1$  is the  $\text{IND}^{\text{HE}}$  game.

$\begin{aligned} & \underline{G_1(1^\kappa, \mathcal{A} = (\mathcal{A}_1, \mathcal{A}_2, \mathcal{A}_3))}: \\ & (\mathbf{x}, \text{st}_1) \leftarrow \mathcal{A}_1(1^\kappa) \\ & \mathbf{k} := A \leftarrow \text{Gen}(1^\kappa, m) \\ & (i \in [m], \mathbf{m}_0, \mathbf{m}_1, \text{st}_2) \leftarrow \mathcal{A}_2(\mathbf{k}, \text{st}_1) \\ & b \leftarrow \{0, 1\} \\ & S \leftarrow \mathbb{Z}_2^{\log^2(\kappa) \times \ell} \\ & E \leftarrow B_\rho^{m \times \ell} \\ & \mathbf{r} \leftarrow R_{\text{WC}} \\ & c_0 := \mathbf{k}_{\text{WC}} \leftarrow \text{Gen}_{\text{WC}}(1^\kappa) \\ & c_1 := A_{-i} S + E_{-i} \\ & c_2 := (\mathbf{h} - (1 - \mathbf{x}_i) \cdot a_i) S + E_i + (\mathbf{m}_b    \mathbf{r}) \cdot G \\ & c_3 := \text{wC}(\mathbf{m}_b, \mathbf{r}) \leftarrow \text{Commit}(\mathbf{k}_{\text{WC}}, \mathbf{m}_b, \mathbf{r}) \\ & b' \leftarrow \mathcal{A}_3(\text{st}_2, \text{ct} = (c_0, c_1, c_2, c_3)) \\ & \text{Return } b = b' \end{aligned}$	$\begin{aligned} & \underline{G_2(1^\kappa, \mathcal{A} = (\mathcal{A}_1, \mathcal{A}_2, \mathcal{A}_3))}: \\ & (\mathbf{x}, \text{st}_1) \leftarrow \mathcal{A}_1(1^\kappa) \\ & \mathbf{k} := A \leftarrow \text{Gen}(1^\kappa, m) \\ & (i \in [m], \mathbf{m}_0, \mathbf{m}_1, \text{st}_2) \leftarrow \mathcal{A}_2(\mathbf{k}, \text{st}_1) \\ & b \leftarrow \{0, 1\} \\ & B \leftarrow \mathbb{Z}_2^{m \times \ell} \\ & \mathbf{r} \leftarrow R_{\text{WC}} \\ & c_0 := \mathbf{k}_{\text{WC}} \leftarrow \text{Gen}_{\text{WC}}(1^\kappa) \\ & c_1 := B_{-i} \\ & c_2 := B_i \\ & c_3 := \text{wC}(\mathbf{m}_b, \mathbf{r}) \leftarrow \text{Commit}(\mathbf{k}_{\text{WC}}, \mathbf{m}_b, \mathbf{r}) \\ & b' \leftarrow \mathcal{A}_3(\text{st}_2, \text{ct} = (c_0, c_1, c_2, c_3)) \\ & \text{Return } b = b' \end{aligned}$
--	--

Fig. 7: The games  $G_1$  and  $G_2$ .

**Lemma 8.** *Let  $\mathcal{A}$  be an adversary that distinguishes  $G_1$  and  $G_2$  with probability  $\epsilon$ . Then there is an algorithm  $\mathcal{A}'$  that breaks the extended hybrid LPN assumption with probability  $\epsilon$ .*

*Proof.* We construct  $\mathcal{A}' = (\mathcal{A}'_1, \mathcal{A}'_2)$  as follows:

$\mathcal{A}'_1(\mathcal{A}_1):$ $(x, \text{st}_1) \leftarrow \mathcal{A}_1(1^\kappa)$ $\text{st}' := (x, \text{st}_1)$ Return $x$	$\mathcal{A}'_2(\text{st}', \mathcal{A}_2, A, B, x^T E):$ $k := A$ $(i \in [m], \mathbf{m}_0, \mathbf{m}_1, \text{st}_2) \leftarrow \mathcal{A}_2(k, \text{st}_1)$ $b \leftarrow \{0, 1\}$ $r \leftarrow \text{R}_{\text{WC}}$ $c_0 := k_{\text{WC}} \leftarrow \text{Gen}_{\text{WC}}(1^\kappa)$ $c_1 := B_{-i}$ $c_2 := B_i + (\mathbf{m}_b    r) \cdot G - x_{-i}^T E_{-i} + x_{-i}^T c_1$ $c_3 := \text{wC}(\mathbf{m}_b, r) \leftarrow \text{Commit}(k_{\text{WC}}, \mathbf{m}_b, r)$ $b' \leftarrow \mathcal{A}_2(\text{st}_2, \text{ct} = (c_0, c_1, c_2, c_3))$ Return $b = b'$
---	---

In the LPN case,  $B = AS + E$ . Therefore  $\mathcal{A}'$  creates  $\text{ct}$  with the same distribution as in game  $\text{IND}^{\text{HE}}$ . This is easy to see for  $c_0, c_3$  and  $c_1 = B_{-i} = A_{-i}S + E_{-i}$ . For  $c_2$ , we have

$$\begin{aligned}
c_2 &= B_i + (\mathbf{m}_b || r) \cdot G - x_{-i}^T E_{-i} + x_{-i}^T c_1 \\
&= a_i S + E_i + (\mathbf{m}_b || r) \cdot G - x_{-i}^T E_{-i} + x_{-i}^T A_{-i} S + x_{-i}^T E_{-i} \\
&= a_i S + E_i + (\mathbf{m}_b || r) \cdot G + x_{-i}^T A_{-i} S \\
&= (\mathbf{h} + (1 - x_i) a_i) S + E_i + (\mathbf{m}_b || r) \cdot G.
\end{aligned}$$

In the uniform case,  $B$  and hence  $c_2$  are uniform. Therefore  $\mathcal{A}'$  simulates  $\mathbf{G}_2$ .  $\mathcal{A}'$  breaks extended hybrid LPN with probability

$$\begin{aligned}
&|\Pr[\mathcal{A}_2(\text{st}', A, AS + E, x, x^T E) = 1] - \Pr[\mathcal{A}_2(\text{st}', A, B, x, x^T E) = 1]| \\
&= |\Pr[\mathbf{G}_1(1^\kappa, \mathcal{A}) = 1] - \Pr[\mathbf{G}_2(1^\kappa, \mathcal{A}) = 1]|.
\end{aligned}$$

□

**Lemma 9.** *If there is an adversary  $\mathcal{A}$  with  $\Pr[\mathbf{G}_2(1^\kappa, \mathcal{A}) = 1] = \frac{1}{2} + \epsilon$ , then there is an algorithm  $\mathcal{A}'$  that breaks the hiding property of  $\text{WC}$  with probability  $2\epsilon$ .*

*Proof.* We construct  $\mathcal{A}'$  as follows.

$\mathcal{A}'_1(k_{\text{WC}}, \mathcal{A}_1, \mathcal{A}_2):$ $(x, \text{st}_1) \leftarrow \mathcal{A}_1(1^\kappa)$ $k := A \leftarrow \text{Gen}(1^\kappa, m)$ $(i \in [m], m_0, m_1, \text{st}_2) \leftarrow \mathcal{A}_2(k, \text{st}_1)$ $\text{st}' := (k_{\text{WC}}, \text{st}_2)$ Return $(m_0, m_1)$	$\mathcal{A}'_2(\text{st}', \mathcal{A}_3, \text{wC}):$ $B \leftarrow \mathbb{Z}_2^{m \times \ell}$ $c_0 := k_{\text{WC}}$ $c_1 := B_{-i}$ $c_2 := B_i$ $c_3 := \text{wC}$ $b' \leftarrow \mathcal{A}_3(\text{st}_2, \text{ct} = (c_0, c_1, c_2, c_3))$ Return $b'$
--	--

It is easy to see that  $\mathcal{A}'$  correctly simulates  $G_2$ . When  $\mathcal{A}$  guesses  $b$  with his guess  $b'$  correctly, then also  $\mathcal{A}'$  does. Therefore

$$\begin{aligned} & \frac{1}{2} \Pr[\mathcal{A}'_2(\text{st}', \text{wC}(m_1, r)) = 1] + \frac{1}{2} \Pr[\mathcal{A}'_2(\text{st}', \text{wC}(m_0, r)) = 0] \\ &= \Pr[G_2(1^\kappa, \mathcal{A}) = 1] = \frac{1}{2} + \epsilon. \end{aligned}$$

Hence,

$$\Pr[\mathcal{A}'_2(\text{st}', \text{wC}(m_1, r)) = 1] - \Pr[\mathcal{A}'_2(\text{st}', \text{wC}(m_0, r)) = 1] = 2\epsilon.$$

□  
□

## 4 Non-compact One-Time Signatures with Encryption

In this Section we will construct a *non-compact* OTSE scheme NC from any public-key encryption scheme  $\text{PKE} = (\text{KeyGen}, \text{Enc}, \text{Dec})$ .

- $\text{SSetup}(1^\kappa, \ell)$ : Output  $\text{pp} \leftarrow \ell$ .
- $\text{SGen}(\text{pp})$ : For  $j = \{1, \dots, \ell\}$  and  $b \in \{0, 1\}$  compute  $(\text{pk}_{j,b}, \text{sk}_{j,b}) \leftarrow \text{PKE.KeyGen}(1^\kappa)$ . Set  $\text{vk} \leftarrow \{\text{pk}_{j,0}, \text{pk}_{j,1}\}_{j \in [\ell]}$  and  $\text{sgk} \leftarrow \{\text{sk}_{j,0}, \text{sk}_{j,1}\}_{j \in [\ell]}$ . Output  $(\text{vk}, \text{sgk})$ .
- $\text{SSign}(\text{pp}, \text{sgk} = \{\text{sk}_{j,0}, \text{sk}_{j,1}\}_{j \in [\ell]}, x)$ : Output  $\sigma \leftarrow \{\text{sk}_{j,x_j}\}_{j \in [\ell]}$ .
- $\text{SEnc}(\text{pp}, (\text{vk} = \{\text{pk}_{j,0}, \text{pk}_{j,1}\}_{j \in [\ell]}, i, b), m)$ : Output  $c \leftarrow \text{PKE.Enc}(\text{pk}_{i,b}, m)$ .
- $\text{SDec}(\text{pp}, (\text{vk}, \sigma = \{\text{sk}_{j,x_j}\}_{j \in [\ell]}, x), c)$ : Output  $m \leftarrow \text{PKE.Dec}(\text{sk}_{i,x_i}, c)$ .

Correctness of this scheme follows immediately from the correctness of PKE.

*Security* We will now establish the  $\text{IND}^{\text{OTSIG}}$ -security of NC from the  $\text{IND}^{\text{CPA}}$ -security of PKE.

**Theorem 5.** *Assume that PKE is  $\text{IND}^{\text{CPA}}$ -secure. Then NC is  $\text{IND}^{\text{OTSIG}}$ -secure.*

*Proof.* Let  $\mathcal{A}$  be a PPT-adversary against  $\text{IND}^{\text{OTSIG}}$  with advantage  $\epsilon$ . We will construct an adversary  $\mathcal{A}'$  against the  $\text{IND}^{\text{CPA}}$  experiment with advantage  $\frac{\epsilon}{2\ell}$ .  $\mathcal{A}'$  gets as input a public key  $\text{pk}$  of the PKE and will simulate the  $\text{IND}^{\text{OTSIG}}$ -experiment to  $\mathcal{A}$ .  $\mathcal{A}'$  first guesses an index  $i^* \xleftarrow{\$} [\ell]$  and a bit  $b^* \xleftarrow{\$} \{0, 1\}$ , sets  $\text{pk}_{i^*, b^*} \leftarrow \text{pk}$  and generates  $2\ell - 1$  pairs of public and secret keys  $(\text{pk}_{j,b}) \leftarrow \text{KeyGen}(1^\kappa)$  for  $j \in [\ell]$  and  $b \in \{0, 1\}$  with the restriction that  $(j, b) \neq (i^*, b^*)$ .  $\mathcal{A}'$  then sets  $\text{vk} \leftarrow \{\text{pk}_{j,0}, \text{pk}_{j,1}\}_{j \in [\ell]}$  and runs  $\mathcal{A}$  on input  $\text{vk}$ . If it holds for the message  $x$  output by  $\mathcal{A}$  that  $x_i = b$ , then  $\mathcal{A}'$  aborts the simulation. Once  $\mathcal{A}$  outputs  $(m_0, m_1, i, b)$ ,  $\mathcal{A}'$  checks if  $(i, b) = (i^*, b^*)$  and if not aborts. Otherwise,  $\mathcal{A}'$  sends the message-pair  $(m_0, m_1)$  to the  $\text{IND}^{\text{CPA}}$ -experiment and receives a challenge-ciphertext  $c^*$ .  $\mathcal{A}'$  now forwards  $c^*$  to  $\mathcal{A}$  and outputs whatever  $\mathcal{A}$  outputs.

First notice that the verification key  $\text{vk}$  computed by  $\mathcal{A}'$  is identically distributed to the verification key in the  $\text{IND}^{\text{OTSIG}}$  experiment. Thus,  $\text{vk}$  does not reveal the index  $i^*$  and the bit  $b^*$ , and consequently it holds that  $(i, b) = (i^*, b^*)$  with probability  $\frac{1}{2\ell}$ . Conditioned on the event that  $(i, b) = (i^*, b^*)$ , it holds that the advantage of  $\mathcal{A}'$  is identical to the advantage of  $\mathcal{A}$ . Therefore, it holds that

$$\text{Adv}_{\text{IND}^{\text{CPA}}}(\mathcal{A}') = \frac{\text{Adv}_{\text{IND}^{\text{OTSIG}}}(\mathcal{A})}{2\ell},$$

which concludes the proof.  $\square$

## 5 Compact One-Time-Signatures with Encryption via Hash-Encryption

In this Section, we will show how a non-compact OTSE scheme NC can be bootstrapped to a compact OTSE scheme OTSE using hash-encryption. Let  $\text{NC} = (\text{SSetup}, \text{SGen}, \text{SSign}, \text{SEnc}, \text{SDec})$  be a non-compact OTSE scheme,  $\text{HE} = (\text{HE.Gen}, \text{HE.Hash}, \text{HE.Enc}, \text{HE.Dec})$  be a hash-encryption scheme and  $(\text{Garble}, \text{Eval})$  be a garbling scheme. The scheme OTSE is given as follows.

- $\text{SSetup}(1^\kappa, \ell)$ : Compute  $\bar{\text{pp}} \leftarrow \text{NC.SSetup}(1^\kappa, \ell)$ ,  $\text{k} \leftarrow \text{HE.Gen}(1^\kappa, \ell')$  (where  $\ell'$  is the size of the verification keys  $\text{vk}$  generated using  $\bar{\text{pp}}$ ) and output  $\text{pp} \leftarrow (\bar{\text{pp}}, \text{k})$ .

- $\text{SGen}(\text{pp} = (\bar{\text{p}}\bar{\text{p}}, k))$ : Compute  $(\bar{\text{v}}k, \bar{\text{s}}gk) \leftarrow \text{NC.SGen}(\bar{\text{p}}\bar{\text{p}})$ . Compute  $\text{h} \leftarrow \text{HE.Hash}(k, \bar{\text{v}}k)$ , set  $\text{vk} \leftarrow \text{h}$ ,  $\text{sgk} \leftarrow (\bar{\text{v}}k, \bar{\text{s}}gk)$  and output  $(\text{vk}, \text{sgk})$ .
- $\text{SSign}(\text{pp} = (\bar{\text{p}}\bar{\text{p}}, k), \text{sgk} = (\bar{\text{v}}k, \bar{\text{s}}gk), \text{x})$ : Compute  $\sigma' \leftarrow \text{NC.SSign}(\bar{\text{p}}\bar{\text{p}}, \bar{\text{s}}gk, \text{x})$ . Output  $\sigma \leftarrow (\bar{\text{v}}k, \sigma')$ .
- $\text{SEnc}(\text{pp} = (\bar{\text{p}}\bar{\text{p}}, k), (\text{vk} = \text{h}, i, b), \text{m})$ : Let  $\text{C}$  be the following circuit.  
 $\text{C}[\bar{\text{p}}\bar{\text{p}}, i, b, \text{m}](\bar{\text{v}}k)$  : Compute and output  $\text{NC.SEnc}(\bar{\text{p}}\bar{\text{p}}, (\bar{\text{v}}k, i, b), \text{m})$ .
  - $(\tilde{\text{C}}, \text{e}_C) \leftarrow \text{Garble}(1^\kappa, \text{C}[\bar{\text{p}}\bar{\text{p}}, i, b, \text{m}])$
  - Parse  $\text{e}_C = \{Y_{j,0}, Y_{j,1}\}_{j \in [\ell']}$
  - $\text{f}_C \leftarrow \{\text{HE.Enc}(k, (\text{h}, j, b'), Y_{j,b'})\}_{j \in [\ell], b' \in \{0,1\}}$
  - Output  $\text{ct} \leftarrow (\tilde{\text{C}}, \text{f}_C)$ .
- $\text{SDec}(\text{pp} = (\bar{\text{p}}\bar{\text{p}}, k), (\text{vk} = \text{h}, \sigma = (\bar{\text{v}}k, \sigma'), \text{x}), \text{ct} = (\tilde{\text{C}}, \text{f}_C))$ :
  - Parse  $\text{f}_C = \{c_{j,b'}\}_{j \in [\ell], b' \in \{0,1\}}$
  - $\tilde{\text{y}} \leftarrow \{\text{HE.Dec}(k, \bar{\text{v}}k, c_{j,y_j})\}_{j \in [\ell]}$
  - $c' \leftarrow \text{Eval}(\tilde{\text{C}}, \tilde{\text{y}})$
  - $\text{m} \leftarrow \text{NC.SDec}(\bar{\text{p}}\bar{\text{p}}, (\bar{\text{v}}k, \sigma', \text{x}), c')$
  - Output  $\text{m}$

*Compactness and Correctness* By construction, the size of  $\text{vk} = \text{HE.Hash}(k, \bar{\text{v}}k)$  depends on  $\kappa$ , but not on  $\ell'$  or  $\ell$ . Therefore, OTSE is compact.

To see that the scheme is correct, note first that since it holds that  $\text{h} = \text{HE.Hash}(k, \bar{\text{v}}k)$  and  $\text{f}_C = \{\text{HE.Enc}(k, (\text{h}, j, b'), Y_{j,b'})\}_{j \in [\ell], b' \in \{0,1\}}$ , by correctness of the hash-encryption scheme HE we have

$$\tilde{\text{y}} = \{\text{HE.Dec}(k, \bar{\text{v}}k, c_{j,y_j})\}_{j \in [\ell]} = \{Y_{j,y_j}\}_{j \in [\ell]}.$$

Thus, as  $(\tilde{\text{C}}, \text{e}_C) = \text{Garble}(1^\kappa, \text{C}[\bar{\text{p}}\bar{\text{p}}, i, b, \text{m}])$  and by the definition of  $\text{C}$ , it holds by the correctness of the garbling scheme (Garble, Eval) that

$$c' = \text{Eval}(\tilde{\text{C}}, \tilde{\text{y}}) = \text{C}[\bar{\text{p}}\bar{\text{p}}, i, b, \text{m}](\bar{\text{v}}k) = \text{NC.SEnc}(\bar{\text{p}}\bar{\text{p}}, (\bar{\text{v}}k, i, b), \text{m}).$$

Finally, as  $\sigma' = \text{NC.SSign}(\bar{\text{p}}\bar{\text{p}}, \bar{\text{s}}gk, \text{x})$  it holds by the correctness of the non-compact OTSE-scheme NC that

$$\text{NC.SDec}(\bar{\text{p}}\bar{\text{p}}, (\bar{\text{v}}k, \sigma', \text{x}), c') = \text{m},$$

which concludes the proof of correctness.

*Security* We will now establish the  $\text{IND}^{\text{OTSIG}}$ -security of OTSE from the security of the hash-encryption scheme HE, the security of the garbling scheme (Garble, Eval) and the  $\text{IND}^{\text{OTSIG}}$ -security of NC.



**Theorem 6.** *Assume that HE is an  $\text{IND}^{\text{HE}}$ -secure hash-encryption scheme, (Garble, Eval) is a secure garbling scheme and NC is  $\text{IND}^{\text{OTSIG}}$ -secure. Then OTSE is an  $\text{IND}^{\text{OTSIG}}$ -secure OTSE-scheme.*

*Proof.* Let  $\mathcal{A}$  be a PPT-adversary against the  $\text{IND}^{\text{OTSIG}}$ -security of OTSE. Consider the following hybrid experiments.

*Hybrid  $\mathcal{H}_0$*  This experiment is identical to  $\text{IND}^{\text{OTSIG}}(\mathcal{A})$ .

*Hybrid  $\mathcal{H}_1$*  This experiment is identical to  $\mathcal{H}_0$ , except that  $f_C$  is computed by  $f_C \leftarrow \{\text{HE.Enc}(k, (h, j, b'), Y_{j,y_j})\}_{j \in [\ell], b' \in \{0,1\}}$ , i.e. for all  $j \in [\ell]$  the message  $Y_{j,y_j}$  is encrypted, regardless of the bit  $b'$ . Computational indistinguishability between  $\mathcal{H}_0$  and  $\mathcal{H}_1$  follows from the  $\text{IND}^{\text{HE}}$ -security of HE. The reduction R first generates the public parameters  $\bar{p}p \leftarrow \text{NC.SSetup}(1^\kappa, \ell)$ , the keys  $(\bar{v}k, \bar{s}gk) \leftarrow \text{NC.SGen}(\bar{p}p)$  and sends  $\bar{v}k$  as its selectively chosen message to the  $\text{IND}^{\text{HE}}$ -experiment. It then obtains  $k$ , computes  $h \leftarrow \text{HE.Hash}(k, \bar{v}k)$  and sets  $pp \leftarrow (\bar{p}p, k)$ ,  $vk \leftarrow h$ ,  $sgk \leftarrow (\bar{v}k, \bar{s}gk)$  and then simulates  $\mathcal{H}_0$  with these parameters with  $\mathcal{A}$ . Instead of computing the ciphertexts  $f_C$  by itself, R sends the labels  $\{Y_{j,0}, Y_{j,1}\}_{j \in [\ell]}$  to the multi-challenge  $\text{IND}^{\text{HE}}$ -experiment and obtains the ciphertexts  $f_C$ . R continues the simulation and outputs whatever  $\mathcal{A}$  outputs. Clearly, if the challenge-bit of R's  $\text{IND}^{\text{HE}}$ -experiment is 0, then from the view of  $\mathcal{A}$  the reduction R simulates  $\mathcal{H}_0$  perfectly. On the other hand, if the challenge-bit is 1, then R simulates  $\mathcal{H}_1$  perfectly. Thus R's advantage is identical to  $\mathcal{A}$ 's distinguishing advantage between  $\mathcal{H}_0$  and  $\mathcal{H}_1$ . It follows that  $\mathcal{H}_0$  and  $\mathcal{H}_1$  are computationally indistinguishable, given the  $\text{IND}^{\text{HE}}$ -security of NC.

*Hybrid  $\mathcal{H}_2$*  This experiment is identical to  $\mathcal{H}_1$ , except that we compute  $\tilde{C}$  by  $(\tilde{C}, \tilde{y}) \leftarrow \text{GCSim}(C, C[\bar{p}p, i, b, m](\bar{v}k))$  and the value and  $f_C$  by  $f_C \leftarrow \{\text{HE.Enc}(k, (h, j, b'), \tilde{y}_j)\}_{j \in [\ell], b' \in \{0,1\}}$ . Computational indistinguishability of  $\mathcal{H}_1$  and  $\mathcal{H}_2$  follows by the security of the garbling scheme (Garble, Eval).

Notice that  $C[\bar{p}p, i, b, m](\bar{v}k)$  is identical to  $\text{NC.SEnc}(\bar{p}p, (\bar{v}k, i, b), m^*)$ . Thus, by the security of the non-compact OTSE-scheme NC, we can argue that  $\mathcal{A}$ 's advantage in  $\mathcal{H}_2$  is negligible.

## 6 KDM-secure Public-Key Encryption

In this section, we will build a  $\text{KDM}^{\text{CPA}}$ -secure public-key encryption scheme from a  $\text{KDM}^{\text{CPA}}$ -secure secret-key encryption scheme and a non-

compact OTSE-scheme. The latter can be constructed from any public-key encryption scheme by the results of Section 4.

Let  $\text{NC} = (\text{SSetup}, \text{SGen}, \text{SSign}, \text{SEnc}, \text{SDec})$  be a non-compact OTSE scheme,  $\text{SKE} = (\text{Enc}, \text{Dec})$  be a  $\text{KDM}^{\text{CPA}}$ -secure secret-key encryption scheme and  $(\text{Garble}, \text{Eval})$  be a garbling scheme. The public-key encryption scheme PKE is given as follows.

- $\text{KeyGen}(1^\kappa)$ : Sample  $k \xleftarrow{\$} \{0, 1\}^\kappa$ , compute  $\text{pp} \leftarrow \text{NC.SSetup}(\kappa)$ , compute  $(\text{vk}, \text{sgk}) \leftarrow \text{NC.SGen}(\text{pp})$  and  $\sigma \leftarrow \text{NC.SSign}(\text{pp}, \text{sgk}, k)$ . Output  $\text{pk} \leftarrow (\text{pp}, \text{vk})$  and  $\text{sk} \leftarrow (k, \sigma)$ .
- $\text{Enc}(\text{pk} = (\text{pp}, \text{vk}), m)$ : Let  $C$  be the following circuit:  $C[m](k)$ : Compute and output  $\text{SKE.Enc}(k, m)$ .<sup>3</sup>

$(\tilde{C}, e_C) \leftarrow \text{Garble}(1^\kappa, C[m])$   
 Parse  $e_C = \{K_{j,0}, K_{j,1}\}_{j \in [\kappa]}$   
 $f_C \leftarrow \{\text{NC.SEnc}(\text{pp}, (\text{vk}, j, b), K_{j,b})\}_{j \in [\kappa], b \in \{0,1\}}$   
 Output  $\text{ct} \leftarrow (\tilde{C}, f_C)$ .

- $\text{Dec}(\text{sk} = (k, \sigma), \text{ct} = (\tilde{C}, f_C))$ :

$\tilde{k} \leftarrow \{\text{NC.SDec}(\text{pp}, (\text{vk}, \sigma, k), f_{C,j,k_j})\}_{j \in [\kappa]}$   
 $c' \leftarrow \text{Eval}(\tilde{C}, \tilde{k})$   
 $m \leftarrow \text{SKE.Dec}(k, c')$   
 Output  $m$

Note in particular that the secret key  $\text{sk}$  does not include the signing key  $\text{sgk}$ .

## 6.1 Correctness

We will first show that the scheme PKE is correct. Let therefore  $(\text{pk}, \text{sk}) \leftarrow \text{PKE.KeyGen}(1^\kappa)$  and  $\text{ct} \leftarrow \text{PKE.Enc}(\text{pk}, m)$ . By the correctness of the OTSE-scheme NC it holds that  $\tilde{k} = \{K_{j,k_j}\}$ . Thus, by the correctness of the garbling scheme it holds that  $\text{ct}' = \tilde{C}[m](k) = \text{SKE.Enc}(k, m)$ . Finally, by the correctness of SKE it holds that  $\text{SKE.Dec}(k, \text{ct}') = m$ .

<sup>3</sup> We also need to hardcode the randomness for  $\text{SKE.Enc}$  into  $C$ , but for ease of notation we omit this parameter.

## 6.2 Security

We will now show that PKE is  $\text{KDM}^{\text{CPA}}$ -secure.

**Theorem 7.** *Assume that NC is an  $\text{IND}^{\text{OTSIG}}$ -secure OTSE-scheme and  $(\text{Garble}, \text{Eval})$  is a secure garbling scheme. Let  $\mathcal{F}$  be a class of KDM-functions and assume that the function  $g_{\text{pp}, \text{sgk}} : x \mapsto (x, \text{NC.SSign}(\text{pp}, \text{sgk}, x))$  is in a class  $\mathcal{G}$  (e.g. affine functions). Assume that SKE is a  $\text{KDM}^{\text{CPA}}$ -secure secret-key encryption scheme for the class  $\mathcal{F} \circ \mathcal{G}$ . Then PKE is a  $\text{KDM}^{\text{CPA}}$ -secure public key encryption scheme for the class  $\mathcal{F}$ .*

Note that if both  $\mathcal{F}$  and  $\mathcal{G}$  are the class of affine functions, e.g. over  $\mathbb{F}_2$ , then  $\mathcal{F} \circ \mathcal{G}$  is again the class of affine functions (over  $\mathbb{F}_2$ ).

*Proof.* Let  $\mathcal{A}$  be a PPT-adversary against the  $\text{KDM}^{\text{CPA}}$ -security of PKE. Consider the following hybrids, in which we will change the way the KDM-oracle is implemented. For sake of readability, we only provide 3 hybrids, where in actuality each hybrid consists of  $q$  sub-hybrids, where  $q$  is the number of KDM-queries of  $\mathcal{A}$ .

*Hybrid  $\mathcal{H}_1$ :* This hybrid is identical to the  $\text{KDM}^{\text{CPA}}$ -experiment.

*Hybrid  $\mathcal{H}_2$ :* This hybrid is identical to  $\mathcal{H}_1$ , except that  $f_C$  is computed by  $f_C \leftarrow \{\text{NC.SEnc}(\text{pp}, (\text{vk}, j, b), K_{j, k_j})\}_{j \in [\kappa], b \in \{0,1\}}$ , i.e. for each  $j \in [\kappa]$  we encrypt  $K_{j, k_j}$  twice, instead of  $K_{j,0}$  and  $K_{j,1}$ . By the  $\text{IND}^{\text{OTSIG}}$ -security of NC the hybrids  $\mathcal{H}_1$  and  $\mathcal{H}_2$  are computationally indistinguishable.

*Hybrid  $\mathcal{H}_3$ :* This hybrid is identical to  $\mathcal{H}_2$ , except that we compute  $\tilde{C}$  and  $f_C$  by  $(\tilde{C}, \tilde{k}) \leftarrow \text{GCSim}(C, C[m](k))$ . Computational indistinguishability between  $\mathcal{H}_2$  and  $\mathcal{H}_3$  follows by the security of the garbling scheme  $(\text{Garble}, \text{Eval})$ . Notice that it holds that  $C[m^*](k) = \text{SKE.Enc}(k, m^*)$ .

We will now show that the advantage of  $\mathcal{A}$  is negligible in  $\mathcal{H}_3$ , due to the  $\text{KDM}^{\text{CPA}}$ -security of SKE. We will provide a reduction R such that  $R^{\mathcal{A}}$  has the same advantage against the  $\text{KDM}^{\text{CPA}}$ -security of SKE as  $\mathcal{A}$ 's advantage against  $\mathcal{H}_3$ .

Before we provide the reduction R, notice that R does not have access to its own challenge secret key  $k$ , which is part of the secret key  $\text{sk} = (k, \sigma)$  of the resulting PKE. Also, since  $\sigma$  is a signature on  $k$ , R does not know the value of  $\sigma$  either. Thus, R cannot on its own simulate encryptions of messages that depend on  $(k, \sigma)$ . We overcome this problem by using the KDM-oracle provided to R which effectively allows R to obtain encryptions of key-dependent messages  $\text{sk} = (k, \sigma)$ . Details follow.

The reduction  $R$  first samples  $\text{pp} \leftarrow \text{NC.SSetup}(\kappa)$  and  $(\text{vk}, \text{sgk}) \leftarrow \text{NC.SGen}(\text{pp})$  and invokes  $\mathcal{A}$  on  $\text{pk} = (\text{pp}, \text{vk})$ . Then  $R$  simulates  $\mathcal{H}_3$  for  $\mathcal{A}$  with the following differences. Whenever  $\mathcal{A}$  queries the KDM-oracle with a function  $f \in \mathcal{F}$ , the reduction  $R$  programs a new function  $f' \in \mathcal{F} \circ \mathcal{G}$  which is defined by

$$f'(k) = f(k, \text{NC.SSign}(\text{pp}, \text{sgk}, k)).$$

We assume for simplicity that the signing procedure  $\text{NC.SSign}$  is deterministic, if not we require that the same randomness  $r$  is used for  $\text{NC.SSign}$  at each KDM-query<sup>4</sup>.

We claim that  $R$  simulates  $\mathcal{H}_3$  perfectly from the view of  $\mathcal{A}$ . If the challenge-bit in  $R$ 's  $\text{KDM}^{\text{CPA}}$ -experiment is 0, then the outputs of  $\mathcal{A}$ 's KDM-oracle on input  $f$  are encryptions of  $f'(k) = f(\text{sk})$ , and therefore, from the view of  $\mathcal{A}$  the challenge-bit in  $\mathcal{H}_3$  is also 0. On the other hand, if the challenge-bit in  $R$ 's  $\text{KDM}^{\text{CPA}}$ -experiment is 1, then the outputs of  $\mathcal{A}$ 's KDM-oracle on input  $f$  are encryptions of  $0^\ell$ , and therefore, from  $\mathcal{A}$ 's view the challenge-bit in  $\mathcal{H}_3$  is 1. We conclude that the advantage of  $R^{\mathcal{A}}$  is identical to the advantage of  $\mathcal{A}$  against  $\mathcal{H}_3$ . It follows from the  $\text{KDM}^{\text{CPA}}$ -security of SKE that the latter is negligible, which concludes the proof.  $\square$

## References

- [ABB10] Shweta Agrawal, Dan Boneh, and Xavier Boyen. Efficient lattice (H)IBE in the standard model. In Henri Gilbert, editor, *EUROCRYPT 2010*, volume 6110 of *LNCS*, pages 553–572, French Riviera, May 30 – June 3, 2010. Springer, Heidelberg, Germany.
- [ABSS93] Sanjeev Arora, László Babai, Jacques Stern, and Z. Sweedyk. The hardness of approximate optima in lattices, codes, and systems of linear equations. In *34th FOCS*, pages 724–733, Palo Alto, California, November 3–5, 1993. IEEE Computer Society Press.
- [ACPS09] Benny Applebaum, David Cash, Chris Peikert, and Amit Sahai. Fast cryptographic primitives and circular-secure encryption based on hard learning problems. In Shai Halevi, editor, *CRYPTO 2009*, volume 5677 of *LNCS*, pages 595–618, Santa Barbara, CA, USA, August 16–20, 2009. Springer, Heidelberg, Germany.
- [Ajt98] Miklós Ajtai. The shortest vector problem in  $L_2$  is NP-hard for randomized reductions (extended abstract). In *30th ACM STOC*, pages 10–19, Dallas, TX, USA, May 23–26, 1998. ACM Press.
- [AP12] Jacob Alperin-Sheriff and Chris Peikert. Circular and KDM security for identity-based encryption. In Marc Fischlin, Johannes Buchmann, and Mark

---

<sup>4</sup> This does not pose a problem as we always sign the same message  $k$  at each KDM-query

- Manulis, editors, *PKC 2012*, volume 7293 of *LNCS*, pages 334–352, Darmstadt, Germany, May 21–23, 2012. Springer, Heidelberg, Germany.
- [App14] Benny Applebaum. Key-dependent message security: Generic amplification and completeness. *Journal of Cryptology*, 27(3):429–451, July 2014.
- [BB04] Dan Boneh and Xavier Boyen. Secure identity based encryption without random oracles. In Matthew Franklin, editor, *CRYPTO 2004*, volume 3152 of *LNCS*, pages 443–459, Santa Barbara, CA, USA, August 15–19, 2004. Springer, Heidelberg, Germany.
- [BF01] Dan Boneh and Matthew K. Franklin. Identity-based encryption from the Weil pairing. In Joe Kilian, editor, *CRYPTO 2001*, volume 2139 of *LNCS*, pages 213–229, Santa Barbara, CA, USA, August 19–23, 2001. Springer, Heidelberg, Germany.
- [BG10] Zvika Brakerski and Shafi Goldwasser. Circular and leakage resilient public-key encryption under subgroup indistinguishability - (or: Quadratic residuosity strikes back). In Tal Rabin, editor, *CRYPTO 2010*, volume 6223 of *LNCS*, pages 1–20, Santa Barbara, CA, USA, August 15–19, 2010. Springer, Heidelberg, Germany.
- [BGH07] Dan Boneh, Craig Gentry, and Michael Hamburg. Space-efficient identity based encryption without pairings. In *48th FOCS*, pages 647–657, Providence, RI, USA, October 20–23, 2007. IEEE Computer Society Press.
- [BH10] Boaz Barak, Iftach Haitner, Dennis Hofheinz, and Yuval Ishai. Bounded key-dependent message security. In Henri Gilbert, editor, *EUROCRYPT 2010*, volume 6110 of *LNCS*, pages 423–444, French Riviera, May 30 – June 3, 2010. Springer, Heidelberg, Germany.
- [BHH08] Dan Boneh, Shai Halevi, Michael Hamburg, and Rafail Ostrovsky. Circular-secure encryption from decision Diffie-Hellman. In David Wagner, editor, *CRYPTO 2008*, volume 5157 of *LNCS*, pages 108–125, Santa Barbara, CA, USA, August 17–21, 2008. Springer, Heidelberg, Germany.
- [BHR12] Mihir Bellare, Viet Tung Hoang, and Phillip Rogaway. Foundations of garbled circuits. In Ting Yu, George Danezis, and Virgil D. Gligor, editors, *ACM CCS 12*, pages 784–796, Raleigh, NC, USA, October 16–18, 2012. ACM Press.
- [CDG<sup>+</sup>17] Chongwon Cho, Nico Döttling, Sanjam Garg, Divya Gupta, Peihan Miao, and Antigoni Polychroniadou. Laconic oblivious transfer and its applications. In Jonathan Katz and Hovav Shacham, editors, *CRYPTO 2017, Part II*, volume 10402 of *LNCS*, pages 33–65, Santa Barbara, CA, USA, August 20–24, 2017. Springer, Heidelberg, Germany.
- [CHKP10] David Cash, Dennis Hofheinz, Eike Kiltz, and Chris Peikert. Bonsai trees, or how to delegate a lattice basis. In Henri Gilbert, editor, *EUROCRYPT 2010*, volume 6110 of *LNCS*, pages 523–552, French Riviera, May 30 – June 3, 2010. Springer, Heidelberg, Germany.
- [CHKP12] David Cash, Dennis Hofheinz, Eike Kiltz, and Chris Peikert. Bonsai trees, or how to delegate a lattice basis. *Journal of Cryptology*, 25(4):601–639, October 2012.
- [Coc01] Clifford Cocks. An identity based encryption scheme based on quadratic residues. In Bahram Honary, editor, *Cryptography and Coding, 8th IMA International Conference*, volume 2260 of *LNCS*, pages 360–363, Cirencester, UK, December 17–19, 2001. Springer, Heidelberg, Germany.
- [DG] Nico Döttling and Sanjam Garg. Identity-based encryption from the diffie-hellman assumption. *Crypto 2017*.

- [DG17a] Nico Döttling and Sanjam Garg. From selective hibe to full hibe and selective hibe. Cryptology ePrint Archive, Report 2017/957, 2017. to appear at TCC 2017.
- [DG17b] Nico Döttling and Sanjam Garg. Identity-based encryption from the Diffie-Hellman assumption. In Jonathan Katz and Hovav Shacham, editors, *CRYPTO 2017, Part I*, volume 10401 of *LNCS*, pages 537–569, Santa Barbara, CA, USA, August 20–24, 2017. Springer, Heidelberg, Germany.
- [GPV08] Craig Gentry, Chris Peikert, and Vinod Vaikuntanathan. Trapdoors for hard lattices and new cryptographic constructions. In Richard E. Ladner and Cynthia Dwork, editors, *40th ACM STOC*, pages 197–206, Victoria, British Columbia, Canada, May 17–20, 2008. ACM Press.
- [GR11] Venkatesan Guruswami and Atri Rudra. Soft decoding, dual BCH codes, and better list-decodable varepsilon-biased codes. *IEEE Trans. Information Theory*, 57(2):705–717, 2011.
- [HILL99] Johan Håstad, Russell Impagliazzo, Leonid A. Levin, and Michael Luby. A pseudorandom generator from any one-way function. *SIAM Journal on Computing*, 28(4):1364–1396, 1999.
- [HR07] Ishay Haviv and Oded Regev. Tensor-based hardness of the shortest vector problem to within almost polynomial factors. In David S. Johnson and Uriel Feige, editors, *39th ACM STOC*, pages 469–477, San Diego, CA, USA, June 11–13, 2007. ACM Press.
- [Kho04] Subhash Khot. Hardness of approximating the shortest vector problem in lattices. In *45th FOCS*, pages 126–135, Rome, Italy, October 17–19, 2004. IEEE Computer Society Press.
- [LLL82] Arjen Klaas Lenstra, Hendrik Willem Lenstra, and László Lovász. Factoring polynomials with rational coefficients. *Mathematische Annalen*, 261(4):515–534, 1982.
- [LP09] Yehuda Lindell and Benny Pinkas. A proof of security of Yao’s protocol for two-party computation. *Journal of Cryptology*, 22(2):161–188, April 2009.
- [LW10] Allison B. Lewko and Brent Waters. New techniques for dual system encryption and fully secure HIBE with short ciphertexts. In Daniele Micciancio, editor, *TCC 2010*, volume 5978 of *LNCS*, pages 455–479, Zurich, Switzerland, February 9–11, 2010. Springer, Heidelberg, Germany.
- [LW15] Vadim Lyubashevsky and Daniel Wichs. Simple lattice trapdoor sampling from a broad class of distributions. In Jonathan Katz, editor, *PKC 2015*, volume 9020 of *LNCS*, pages 716–730, Gaithersburg, MD, USA, March 30 – April 1, 2015. Springer, Heidelberg, Germany.
- [Mic98] Daniele Micciancio. The shortest vector in a lattice is hard to approximate to within some constant. In *39th FOCS*, pages 92–98, Palo Alto, CA, USA, November 8–11, 1998. IEEE Computer Society Press.
- [MP12] Daniele Micciancio and Chris Peikert. Trapdoors for lattices: Simpler, tighter, faster, smaller. In David Pointcheval and Thomas Johansson, editors, *EUROCRYPT 2012*, volume 7237 of *LNCS*, pages 700–718, Cambridge, UK, April 15–19, 2012. Springer, Heidelberg, Germany.
- [MR04] Daniele Micciancio and Oded Regev. Worst-case to average-case reductions based on Gaussian measures. In *45th FOCS*, pages 372–381, Rome, Italy, October 17–19, 2004. IEEE Computer Society Press.
- [Reg05] Oded Regev. On lattices, learning with errors, random linear codes, and cryptography. In Harold N. Gabow and Ronald Fagin, editors, *37th ACM STOC*, pages 84–93, Baltimore, MA, USA, May 22–24, 2005. ACM Press.

- [Sha84] Adi Shamir. Identity-based cryptosystems and signature schemes. In G. R. Blakley and David Chaum, editors, *CRYPTO'84*, volume 196 of *LNCS*, pages 47–53, Santa Barbara, CA, USA, August 19–23, 1984. Springer, Heidelberg, Germany.
- [Wat05] Brent R. Waters. Efficient identity-based encryption without random oracles. In Ronald Cramer, editor, *EUROCRYPT 2005*, volume 3494 of *LNCS*, pages 114–127, Aarhus, Denmark, May 22–26, 2005. Springer, Heidelberg, Germany.
- [Wat09] Brent Waters. Dual system encryption: Realizing fully secure IBE and HIBE under simple assumptions. In Shai Halevi, editor, *CRYPTO 2009*, volume 5677 of *LNCS*, pages 619–636, Santa Barbara, CA, USA, August 16–20, 2009. Springer, Heidelberg, Germany.
- [Yao82] Andrew Chi-Chih Yao. Protocols for secure computations (extended abstract). In *23rd FOCS*, pages 160–164, Chicago, Illinois, November 3–5, 1982. IEEE Computer Society Press.
- [YZ16] Yu Yu and Jiang Zhang. Cryptography with auxiliary input and trapdoor from constant-noise LPN. Cryptology ePrint Archive, Report 2016/514, 2016. <http://eprint.iacr.org/2016/514>.