

Greco: Fast Zero-Knowledge Proofs for Valid FHE RLWE Ciphertexts Formation

Enrico Bottazzi
Ethereum Foundation
`enrico@pse.dev`

Abstract

Fully homomorphic encryption (FHE) allows for evaluating arbitrary functions over encrypted data. In Multi-party FHE applications, different parties encrypt their secret data and submit ciphertexts to a server, which, according to the application logic, performs homomorphic operations on them. For example, in a secret voting application, the tally is computed by summing up the ciphertexts encoding the votes. Valid encrypted votes are of the form $E(0)$ and $E(1)$. A malicious voter could send an invalid encrypted vote such as $E(145127835)$, which can mess up the whole election. Because of that, users must prove that the ciphertext they submitted is a valid Ring-Learning with Errors (RLWE) ciphertext and that the plaintext message they encrypted is a valid vote (for example, either a 1 or 0). Greco uses zero-knowledge proof to let a user prove that their RLWE ciphertext is well-formed. Or, in other words, that the encryption operation was performed correctly. The resulting proof can be, therefore, composed with additional application-specific logic and subject to public verification in a non-interactive setting. Considering the secret voting application, one can prove further properties of the message being encrypted or even properties about the voter, allowing the application to support anonymous voting as well. The prover has been implemented using Halo2-lib as a proving system, and the benchmarks have shown that Greco can already be integrated into user-facing applications without creating excessive friction for the user. The implementation is available at <https://github.com/privacy-scaling-explorations/greco>

1 Introduction

Fully homomorphic encryption (FHE) allows for evaluating arbitrary functions over encrypted data. One of the most common applications of FHE is confidential outsourcing of computation. A user can encrypt their data, send it to a server that performs the (intensive) computation, and return the encrypted result. In this scenario, the user is the only one affected by the outcome of the computation, so it is not necessary for them to prove that the submitted ciphertext to the server is properly formed.

However, there are other applications of FHE in which the submitted ciphertexts are coming from different parties, such as sealed bid auctions, secret voting (namely, the vote is hidden), or FHE-EVMs [Zam23]. In such applications, a party (or a network of parties) receives the ciphertexts and performs computation on top of them. The result of this computation is then decrypted. In these multi-party applications, the result is affecting more than one user. Each party must prove that they submitted a well-formed ciphertext in these scenarios. Otherwise,

the final result might be, unknowingly to the other participants, constructed from invalid data. Furthermore, key recovery attacks can be mounted if malformed ciphertexts are decrypted, assuming the resulting decryptions are shared with the attacker.

For example, in a secret voting application, the tally is computed by summing up the encrypted votes. Valid encrypted votes are of the form $E(0)$ and $E(1)$. But here’s the trick; since the votes are encrypted, the application cannot tell the difference between a valid encrypted vote such as $E(1)$ and an invalid encrypted vote such as $E(145127835)$, which can mess up the whole election. Because of that, users must prove that (1) the ciphertext they submitted is a valid ciphertext. This might not be enough for the requirements of the application. Users should also prove that (2) the plaintext message they encrypted is a valid vote (for example, either a 1 or 0).

Greco allows users to prove the validity of a FHE Ring-Learning with Errors (RLWE) ciphertext. Greco makes use of zero-knowledge proof to let a user prove that their ciphertext is well-formed. Or, in other words, that the encryption operation was performed correctly. The resulting proof can be, therefore, composed with additional application-specific logic and subject to public verification in a non-interactive setting. Considering the secret voting application, one can prove further properties of the message being encrypted or even properties about the voter, allowing the application to support anonymous voting as well.

The paper focuses on BFV [Bra12] [FV12] Secret Key Encryption and, eventually, extends the scheme to Public Key Encryption. Note that all the techniques described in this document can be easily applied to generate proof of correctness for any FHE scheme based on Ring Learning with Errors (RLWE) and to other RLWE-based algorithms such as Key Generation and Public/Secret Key Decryption.

The implementation of the techniques described hereafter is available as an opensource repository at <https://github.com/privacy-scaling-explorations/greco>

The logic for the BFV implementation at the core of Greco is based on [KPZ21] and [HPS19]. The techniques employed to generate a proof of ciphertext correctness are inspired on [PLS19].

The main tricks employed when designing Greco are the following:

- Leveraging the Chinese Remainder Theorem to represent big integers coefficients via a set of single-precision integers of the size of 60 bits and embedding the ring reduction in the polynomial definition allows avoiding performing non-native arithmetic operations inside the field Z_p in which the elements of the circuit (witness) are defined.
- Constraining polynomial multiplication with a 2-phase challenge circuit design with $O(n)$ complexity, dramatically reducing the cost of polynomial multiplication constrained with the direct method $O(n^2)$.

The circuit has been implemented using Halo2-lib [Axi23a] as a proving system, and the results have shown that Greco can already be integrated into user-facing applications without creating excessive friction for the user. As an example, for parameters $\log Q = 27$ and $n = 1024$ targeting 128-bits of security according to the Homomorphic Encryption Standard [Alb+22], the prover time is equal to 685 ms benchmarked on an M2 Laptop. The verification time is extremely fast, around 3 ms.

Learnings from previous implementations such as zk-fhe [BN23] and Sunscreen zkp backend [Sun22] informed many of the design decisions adopted in Greco.

2 BFV

BFV is a leveled FHE scheme based on the RLWE problem. A comprehensive and easy-to-digest introduction to the BFV scheme is available at [Inf21]. This section is focused on the setup of a BFV scheme in its Residue Number System (RNS) setting and only its secret key encryption algorithm.

Let Q be the ciphertext modulus and t be the plaintext modulus. Let R_Q denote the polynomial ring $\frac{Z_Q[X]}{X^N+1}$. In practice, we leverage RNS and use the Chinese Remainder Theorem (CRT) setting $Q = \prod q_i$ where $\log q_i < 61$ and the q_i factor are pairwise coprime. This modification was originally suggested by [Baj+17] to make arithmetic operations faster as these no longer need to work with Big integer arithmetic. Note that Q and t are co-prime. Furthermore, each q_i can be chosen as a prime number to leverage NTT to achieve fast polynomial multiplication. Using this technique, an integer $x \in Z_Q$ can be represented by its CRT components $\{x_i = x \bmod q_i \in Z_{q_i}\}_i$, and operations on x in Z_Q can be implemented by applying the same operations to each CRT component x_i in its own ring Z_{q_i} . The secret key encryption of a message M is defined as:

$$Ct = (Ct_0, Ct_1) = ([A \cdot s + E + K]_Q, -A)$$

Where $A \leftarrow R_Q, s \leftarrow \chi_{key}, E \leftarrow \chi_{error}$ and $K = \lceil \frac{Q[M]_t}{t} \rceil$ (as described in section 3.1 of [KPZ21]).

Given that Q and t are co-prime (refer to Appendix A for more information), one can calculate K directly in RNS using the equality

$$\lceil \frac{Q[M]_t}{t} \rceil = \frac{Q[M]_t - [QM]_t}{t} = -t^{-1}[QM]_t \pmod{q_i}$$

We will denote the scalar $-t^{-1}$ with K_0 as the negative integer of the multiplicative inverse of $t \pmod{q_i}$ and the polynomial $[QM]_t$ with K_1 .

Therefore,

$$Ct_i = (Ct_{0,i}, Ct_{1,i}) = ([A_i \cdot s + E + K_{0,i}K_1]_{q_i}, -A_i)$$

Where i indicates the i -th CRT decomposition of the ciphertext Ct in the basis q_i , operations in R_q are implemented directly in CRT representation. Note that when working in the RNS setting, uniform elements $A \leftarrow R_Q$ are chosen directly in the CRT basis by drawing uniform values $A_i \leftarrow R_{q_i}$ for each i -th CRT decomposition (section 4.3 of [HPS19]).

3 Proof of Valid Ciphertext Formation

3.1 zkSNARK Logic

Generating a proof of valid ciphertext formation of a message polynomial M under the BFV secret key encryption algorithm requires translating the algorithm into a zkSNARK Circuit. The zero-knowledge property allows the prover to generate such proof without revealing any detail related to secret inputs, such as the secret key s or the message M . The snark property

allows for fast and succinct verification of such proof. The main challenge that appears when translating an FHE algorithm into a zkSNARK circuit is the different groups in which the element of the circuit and the coefficients of the polynomials involved in the FHE scheme live:

- The elements of a circuit are defined in a group G of order p , Z_p . All the operations inside a circuit are performed $\pmod p$.
- The coefficients of $Ct_{0,i}$ are defined in the group Z_{q_i} . All the polynomial operations are performed in the ring R_{q_i} , namely modulo the cyclotomic polynomial $X^N + 1$.

The assumption is that $Q = \prod q_i$ where $\log q_i < 61$ and $\forall q_i, q_i \ll p$. This assumption is required to avoid the coefficients of the polynomial ever overflowing the prime p and potentially pass the range checks constraints (more on that later) even if when they shouldn't. The polynomial ring $\frac{Z_{q_i}[X]}{X^N+1}$ is denoted as R_{q_i} . Any polynomial $H \in R_Q$ is represented via its CRT components $H_i \in R_{q_i}$. Polynomial multiplications and additions in the ring $Z_{q_i}[X]/X^N + 1$ are operations that are non-native to the prime field of the circuit, therefore these operations are really expensive. The main trick employed here to alleviate the cost of such operations is to embed the ring reduction inside the polynomial definition. For example, the modulo reduction of $y = z \pmod n$ can be constrained inside the circuit as $y = q \cdot n + z$ with q that can be pre-computed outside the circuit. Let's first outline the operation that needs to be verified and therefore translated into circuit constraints:

$$A_i \cdot s + E + K_{0,i}K_1 = Ct_{0,i} \pmod{R_{q_i}}$$

Note that no check needs to be performed on the correct formation of $Ct_{1,i}$ since this is equal to the negative of the public sampled polynomial A_i .

And define

$$A_i \cdot s + E + K_{0,i}K_1 = \hat{Ct}_{0,i}$$

Where $\hat{Ct}_{0,i}$ is $Ct_{0,i}$ before the reduction inside the ring R_{q_i} such that

$$\hat{Ct}_{0,i} = Ct_{0,i} \pmod{R_{q_i}}$$

One can express the equation above $\pmod{Z_{q_i}}$ as:

$$\hat{Ct}_{0,i} = Ct_{0,i} - R_{2,i}(X^N + 1) \pmod{Z_{q_i}}$$

Where $(X^N + 1)$ is the cyclotomic polynomial that defines the ring of the ciphertext space. One can further express the equation in Z as:

$$\hat{Ct}_{0,i} = Ct_{0,i} - R_{2,i}(X^N + 1) - R_{1,i}q_i$$

Since $q_i \ll p$, the equation stays unchanged in Z_p :

$$\hat{Ct}_{0,i} = Ct_{0,i} - R_{2,i}(X^N + 1) - R_{1,i}q_i \pmod{Z_p}$$

Or, in its extended form:

$$Ct_{0,i} = A_i \cdot s + E + K_{0,i}K_1 + R_{2,i}(X^N + 1) + R_{1,i}q_i \pmod{Z_p}$$

Note that the relation is true in Z_p , the domain of the elements of the circuit, without having to perform any further reduction or non-native arithmetic operations. To prove that $Ct_{0,i}$ is correctly formed, it is needed to prove that the equation above holds. This can be rewritten using matrices as follows:

$$[A_i \quad 1 \quad K_{0,i} \quad (X^N + 1) \quad q_i] \times \begin{bmatrix} s \\ E \\ K_1 \\ R_{2,i} \\ R_{1,i} \end{bmatrix} = Ct_{0,i}$$

or

$$U_i \times S_i = Ct_{0,i}$$

One naive way to render this relation in a zkSNARK constraint would be to perform the matrix multiplication inside the circuit and expose the matrix U_i and the resulting ciphertext $Ct_{0,i}$ as public inputs. This approach involves many multiplications between large-degree polynomials. In particular, considering two polynomials f and g of degree n , performing the polynomial multiplications $fg = h$ using the direct method would generate:

- $(n + 1)^2$ multiplication constraints (refer to Appendix B for more information)
- n^2 addition constraints (refer to Appendix B for more information)

A more efficient way to perform the polynomial multiplications inside the circuit would be to evaluate the polynomials f , g , and h at a random point γ and enforce that $f(\gamma) * g(\gamma) = h(\gamma)$ which would be true if $fg = h$ according to Schwartz-Zippel lemma. This would generate:

- n multiplication constraints and n addition constraints to evaluate $f(\gamma)$
- n multiplication constraints and n addition constraints to evaluate $g(\gamma)$
- $2n$ multiplication constraints and $2n$ addition constraints to evaluate $f(\gamma)$

With this trick, the complexity of constraining a polynomial multiplication is reduced from $O(n^2)$ to $O(n)$.

The constraint is then reduced to proving that.

$$[A_i(\gamma) \quad 1 \quad K_{0,i} \quad (\gamma^N + 1) \quad q_i] \times \begin{bmatrix} s(\gamma) \\ E(\gamma) \\ K_1(\gamma) \\ R_{2,i}(\gamma) \\ R_{1,i}(\gamma) \end{bmatrix} = Ct_{0,i}(\gamma)$$

or

$$U_i(\gamma) \times S_i(\gamma) = Ct_{0,i}(\gamma) \tag{1}$$

The approach of verifying that the polynomial relation holds by evaluating if it holds at γ was first introduced by [PLS19]. They propose an interactive protocol in which the prover first

commits to the secret matrix S_i and, after receiving the challenge γ from the verifier, the prover will then prove that the coefficients of the polynomials of S_i are in the expected range and prove that (1) holds.

In order to make the approach non-interactive, the strategy adopted by Greco is to leverage the Fiat-Shamir heuristic as follows:

1. Fill the witness table with the secret polynomials of S_i during the **first phase** of proof generation
2. Extract the commitment of the witness so far and hash it to generate the challenge γ
3. Prove that the coefficients of the polynomials of S_i are in the expected range during the **second phase** of proof generation
4. Use the challenge γ to prove that (1) holds during the **second phase** of proof generation

Note that since the polynomials inside the U_i matrix are public, and so is the polynomial $Ct_{0,i}$, it is possible to directly pass their evaluations at γ as public input of the circuit to the second phase. The same does not apply to the polynomials of S_i : for those polynomials, their evaluations at γ need to be constrained inside the circuit. Since the polynomials written inside the matrix S_i are private, it is also necessary to check that their coefficients live in the expected range. For a thorough analysis of the expected range of the matrix S_i polynomial coefficients, check paragraph 3.3. Proof of valid encryption of a message polynomial M under the BFV secret key encryption scheme requires incorporating the operations that define the algorithm inside a ZK SNARK Circuit. This can be done by writing the following constraints:

- The coefficients of the matrix S_i live in the expected range.
- $U_i(\gamma) \times S_i(\gamma) = Ct_{0,i}(\gamma)$

3.2 Calculating $R_{1,i}$ and $R_{2,i}$

$R_{1,i}$ and $R_{2,i}$ can be precomputed outside of the circuit as follows:

Since

$$C\hat{t}_{0,i} = Ct_{0,i} - R_{2,i}(X^N + 1) \pmod{Z_{q_i}}$$

Therefore

$$R_{2,i} = \frac{Ct_{0,i} - C\hat{t}_{0,i}}{(X^N + 1)} \pmod{Z_{q_i}}$$

Since $\deg(X^N + 1) = N$ and $\deg(C\hat{t}_{0,i}) = 2(N - 1)$, therefore $\deg(R_{2,i}) = 2(N - 1) - N = N - 2$.

Since

$$C\hat{t}_{0,i} = Ct_{0,i} - R_{2,i}(X^N + 1) - R_{1,i}$$

Therefore

$$R_{1,i} = \frac{Ct_{0,i} - C\hat{t}_{0,i} - R_{2,i}(X^N + 1)}{q_i}$$

Since $\deg(C\hat{t}_{0,i}) = 2(N - 1)$, the degree of the numerator is $2(N - 1)$, therefore $\deg(R_{1,i}) = 2(N - 1)$.

3.3 Range Checks

The goal here is to define the expected range of the coefficients of the polynomials included in the matrix S_i . Defining the ranges would allow us to write the related constraints. Any malicious prover that is trying to generate a ciphertext starting from invalid secret polynomials would not be able to generate a valid proof. In particular, these polynomials are

$$\begin{bmatrix} s \\ E \\ K_1 \\ R_{2,i} \\ R_{1,i} \end{bmatrix}$$

These ranges are:

- $s = [-1, 1]$
- $E = [-B, B]$
- $K_1 = [-\frac{t-1}{2}, \frac{t-1}{2}]$
- $R_{2,i} = [-\frac{q_i-1}{2}, \frac{q_i-1}{2}]$
- $R_{1,i} = [\frac{-((N+2) \cdot \frac{q_i-1}{2} + B + \frac{t-1}{2} \cdot |K_{0,i}|)}{q_i}, \frac{(N+2) \cdot \frac{q_i-1}{2} + B + \frac{t-1}{2} \cdot |K_{0,i}|}{q_i}]$

Refer to Appendix C for more information about this range check analysis. Note that when assigned to the circuit, the coefficients of the polynomial must be in the prime field $[0, p)$. Negative coefficients $-z$ are assigned as field elements $p - z$. Let's take the polynomial E as an example. The coefficients of E live in the range $[-B, B]$. This means that when assigned to the circuit, the coefficients of E must live in the ranges $[0, B]$ or $[-B, p)$. Enforcing the range check in this manner has the downside of requiring the performance of two range checks and adding an additional OR constraint to that. A more efficient way to perform such a range check is to normalize the coefficients such that the coefficients of E must live in the range $[0, 2B]$. The normalization is constrained inside the circuit by adding B to each coefficient of E . Note that the range check is secure as long as $2B < p$. This normalize operations before performing the actual range check is constraint to each of the polynomial of S_i . In general, for each secret polynomial, given their upper bound Ub , the relation $2Ub < p$ must hold in order to avoid any overflow issue. This is true under the assumption $\log q_i < 61$.

3.4 Proving Correctness of k Ciphertexts

In the RNS setting of BFV, each ciphertext Ct defined in the ring R_Q is represented using its CRT components $\{Ct = Ct_i \bmod R_{q_i}\}_i$. Given the assumption that $Q = \prod q_i$ where $\log q_i < 61$, this allows the encryption to be performed more efficiently by performing single-precision integers arithmetic operations instead of big integers.

In particular, considering the encryption operation, small integers such as noise and key coefficients are drawn from χ_{error} and χ_{key} as single-precision integers, while uniform elements

in a, Z_q are chosen directly in the CRT basis by drawing uniform values a_i, Z_{q_i} for all i . All the operations that are supposed to be performed in Z_q are performed in Z_{q_i} for each i -th decomposition.

To prove the correct computation of a ciphertext starting from a message, it is needed to prove the computation of each of the k ciphertexts Ct_{q_i} . There are two ideas that can be explored here.

3.4.1 Parallel Proof Generation

This means that a proof of correct encryption needs to be generated for each i . The good news is that these proofs can be generated in parallel. Furthermore, these proofs (for each Z_{q_i}) can eventually be aggregated in a single proof that verifies the encryption for each smaller modulus. In this way, the user only has to verify a single proof.

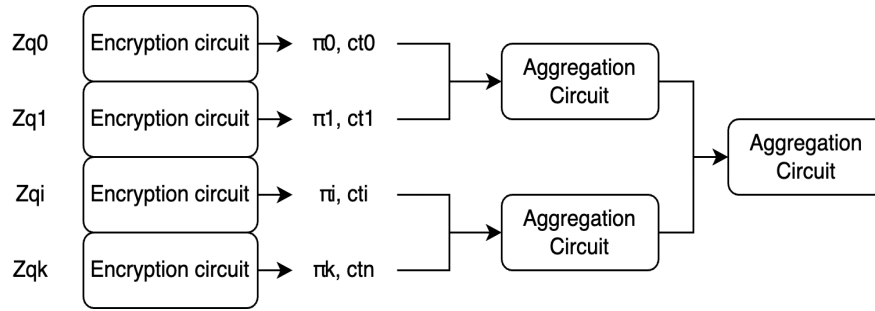

Figure 1: Proof aggregation design

When performing the first recursion, it is important to check whether the common polynomials across each i -th encryption circuit are matching. These polynomials are S, E, K_1

3.4.2 Proving the correctness of multiple ciphertexts in the same proof

Apparently, this approach seems to be the naive version of approach 1. In reality, there are some benefits to this approach, too. In the previous approach, the constraints on the common polynomials S, E , and K_1 are enforced within each i -th encryption circuit. These constraints are the range checks on these polynomials and the evaluation at γ (which will be different for each i -th circuit) of these polynomials. In the previous approach, there are, therefore, some constraints duplicated n times over the same polynomials. In this second approach, the correctness of the n ciphertexts is proven inside a single circuit. In this way, the constraints over S, E , and K_1 are applied only once. In practice, the snark is designed as follows:

- Commit the polynomials of each S_i matrix during the **first phase**. Since S, E, K_1 are common to each S_i matrix, these are committed only once.
- Extract the commitment of the witness so far and hash it to generate the challenge γ
- Prove that the coefficients of the polynomials of each S_i matrix are in the expected range during the **second phase**. Here, the range checks on the polynomials S, E , and K_1 have to be performed only once.

- Use the challenge γ to prove that (1) holds during the **second phase** for each i -th ciphertext. Again, the evaluation of $S(\gamma)$, $E(\gamma)$, $K_1(\gamma)$ need to be constrained only once and then reused across each i -th (1) relation.

Given that k is generally very small, this approach allows us to save some duplicated constraints and the overhead given by the recursion approach. On the other side, it sacrifices the parallelization benefit given by the recursion-based approach.

3.5 Circuit Implementation

The circuit logic is split between **phase0** and **phase1**. The implementation details are based on the setting described in the paragraph 3.4.2. Note that setting k to 1 would result in a proof of a single ciphertext. Parameters such as k (the number of ciphertexts), the degree of the cyclotomic polynomial defining the ring N , the range check bounds and the values of the scalars `qis[]` and `k0is[]` must be defined during key generation and are encoded into the constraining structure of the circuit since then. This implies that each tuple $(n, \text{qis}[], \tau)$ results in different circuit artifacts.

3.5.1 Phase 0

In this phase, the polynomials of each matrix S_i are assigned to the circuit. Namely:

- polynomials `s`, `e` and `k1` are assigned to the witness table. This has to be done only once, as these polynomials are common to each S_i matrix
- polynomials `r1i` and `r2i` are assigned to the witness table for each S_i matrix

Witness values are elements of the finite field $\text{mod } p$. Negative coefficients $-z$ are assigned as field elements $p - z$. At the end of phase 0, the witness generated so far is interpolated into a polynomial and committed by the prover. The hash of this commitment is used as a challenge and will be used as a source of randomness γ in Phase 1. This feature is made available by Halo2 Challenge API [Axi23b].

3.5.2 Phase 1

In this phase, the following constraints are enforced:

1. The coefficients of each matrix S_i are in the expected range.
2. $U_i(\gamma) \times S_i(\gamma) = Ct_{0,i}(\gamma)$.

The first step is to assign the polynomials to the circuit.

- Assign evaluations to the circuit: `ai(gamma)`, `ct0i(gamma)` for each U_i matrix
- Assign `cyclo(gamma)` to the circuit. This has to be done only once, as the cyclotomic polynomial is common to each U_i matrix
- Expose `ai(gamma)`, `ct0i(gamma)` for each U_i matrix
- Expose `'cyclo(gamma)` as public input

Since the polynomials `cyclo`, `ai`, `ct0i` are known to the verifier, the evaluation at γ doesn't need to be constrained inside the circuit. Instead, this can be safely performed (and verified) outside the circuit.

The second step is to perform the range checks. The coefficients of the private polynomials from each i -th matrix S_i are checked to be in the correct range:

- Range check polynomials `s`, `e`, `k1`. This has to be done only once, as these polynomials are common to each S_i matrix
- Range check polynomials `r1i`, `r2i` for each S_i matrix

Since negative coefficients $-z$ are assigned as $p - z$ to the circuit, this might result in very large coefficients. Performing the range check on such large coefficients requires large lookup tables. To avoid this, the coefficients (both negative and positive) are normalized by adding to their upper bound Ub to make the resulting coefficient in the range $[0, 2Ub]$, and then the range check is performed.

The third step is to constrain the evaluation at γ . Contrary to the polynomials `cyclo`, `ai`, `ct0i`, the polynomials belonging to each S_i matrix are not known by the verifier. Therefore, their evaluation at γ must be constrained inside the circuit.

- Constrain the evaluation of the polynomials `s`, `e`, `k1` at γ . This has to be done only once, as these polynomials are common to each S_i matrix
- Constrain the evaluation of the polynomials `r1i`, `r2i` at γ for each S_i matrix

The last step is to enforce the constraint of correct encryption. In other words to prove that $U_i(\gamma) \times S_i(\gamma) = Ct_{0,i}(\gamma)$. This can be rewritten as

$$ct0i = ct0ihat + r1i * qi + r2i * cyclo$$

where

$$ct0ihat = ai * s + e + k1 * k0i$$

This constraint is enforced by proving that $LHS(\gamma) = RHS(\gamma)$. According to the Schwartz-Zippel lemma, if this relation between polynomials, when evaluated at a random point, holds true, then the polynomials are identical with overwhelming probability. Note that `qi` and `k0i` (for each U_i matrix) are constants to the circuit encoded during key generation.

Therefore, the constrain to be enforced for each i -th CRT basis is :

$$ct0i(\gamma) = ai(\gamma) * s(\gamma) + e(\gamma) + k1(\gamma) * k0i + r1i(\gamma) * qi + r2i(\gamma) * cyclo(\gamma)$$

4 Prover and Verifier Scheme

This section describes the main algorithms of the Greco prover and verifier Scheme.

$$\text{Greco.KeyGen}(\lambda) = pk, vk$$

The application developer chooses the parameters for the FHE scheme, given the security parameters and the required fhe circuit depths identified by λ . These are the parameters t, Q, n, σ and B . [Alb+22] provides a good basis for choosing such parameters. In particular, the document fixes the standard deviation of the Gaussian distribution used for error polynomial sampling $\sigma \approx 3.2$ and the bound of the distribution $B \approx 19$. Hence, only the ring degree n and the plaintext and ciphertext space moduli t and Q remain to be determined. These parameters are encoded into the zk circuit to generate the proving key pk and the verification vk . Note that different applications might have different security and depth requirements. Therefore, the artifacts pk and vk can not be reused for different applications. The chosen parameters should be known to everybody.

$$\text{BFV.SecretKeyGen}() = s$$

The user generates a secret key s , where s is a polynomial sampled from the ternary distribution χ_{key} .

$$\text{BFV.SecretKeyEncrypt}(s, m) = Ct$$

Sample A and E and outputs the ciphertext

$$Ct = (Ct_0, Ct_1) = ([A \cdot s + E + K_0 K_1]_Q, -A)$$

Where $A \leftarrow R_Q, s \leftarrow \chi_{key}, E \leftarrow \chi_{error}$ and $K_0 = -t^{-1}$ and $K_1 = [QM]_t$.

The user performs the encryption and shares Ct with the verifier.

$$\text{Greco.Prove}(U, S, Ct_0, pk) = \pi, pub$$

The prover builds the matrices U and S and uses the proving key pk to generate a proof π that Ct_0 is a well-formed ciphertext. The inputs $A(\gamma)$, $Ct_0(\gamma)$ and $\gamma^n + 1$, encapsulated in the variable pub , are shared to the public.

$$\text{Greco.Verify}(\pi, pub, vk) = 1/0$$

The verifier performs the verification of the cryptographic proof π via the vk . On top of that, further checks are required on the correctness of the public inputs pub . The verifier should re-generate γ starting from the proof transcript and evaluate that the evaluation of the public polynomials Ct_0 , A and the cyclotomic polynomial $x^n + 1$ at γ matches pub .

5 Public Key Encryption Extension

BFV Public Key Encryption is built, similarly to Secret Key Encryption, using RLWE. The public key is generated as

$$Pk = (Pk_0, Pk_1) = ([A \cdot s + E]_Q, -A)$$

Or, if operating in RNS setting,

$$Pk_{q_i} = (Pk_{0,q_i}, Pk_{1,q_i}) = ([A_i \cdot s + E]_{q_i}, -A_i)$$

Where $A_i \leftarrow R_{q_i}, S \leftarrow \chi_{key}, E \leftarrow \chi_{error}$

Encryption is performed as follows:

$$Ct_{q_i} = (Ct_{0,q_i}, Ct_{1,q_i}) = ([Pk_{0,q_i} \cdot U + E_0 + K_i]_{q_i}, [Pk_{1,q_i} \cdot U + E_1]_{q_i})$$

Where $U \leftarrow \chi_{key}$ and $E_0, E_1 \leftarrow \chi_{error}$.

As you can notice, generating $Ct_{0,q_i} = [Pk_{0,q_i} \cdot U + E_0 + K_i]_{q_i}$ resembles the ciphertext Ct_{0,q_i} generated during BFV secret key encryption $Ct_{0,q_i} = [A_i \cdot s + E + K]_{q_i}$. The exact same technique described above by replacing A_i, s and E , with Pk_{0,q_i}, U and E_0 can be used to prove the correct formation of Ct_{0,q_i} as result of public key BFV encryption. Or using the matrix notation, this can be expressed as follow:

$$\begin{bmatrix} Pk_{0,q_i} & 1 & K_{0,i} & (X^N + 1) & q_i \end{bmatrix} \times \begin{bmatrix} U \\ E_0 \\ K_1 \\ R_{2,i} \\ R_{1,i} \end{bmatrix} = Ct_{0,i}$$

The range check defined in paragraph 3.3 equally apply for the secret matrix polynomial for Public Key Encryption.

On top of that, further checks need to be performed on Ct_{1,q_i} specifically that:

- E_1 lives in the expected range
- $[Pk_{1,q_i} \cdot U + E_1]_{q_i} = Ct_{1,q_i}$

To prove this, we adapt the technique described above as follow:

$$\begin{bmatrix} Pk_{1,q_i} & 1 & (X^N + 1) & q_i \end{bmatrix} \times \begin{bmatrix} U \\ E_1 \\ P_{2,i} \\ P_{1,i} \end{bmatrix} = Ct_{0,i}$$

The calculation of $P_{2,i}$ and $P_{1,i}$ and of the required ranges of the secret polynomials is left as an exercise to the reader.

6 Composability with Application-Specific Logic

In the example of a secret voting application, the user must prove that (1) the ciphertext they submitted is a valid ciphertext. (2) the plaintext they encrypted is a valid vote (for example, either a 1 or 0). Up until now, the discussion has only concerned the first type of proof. From a theoretical level, the circuit can be extended to prove any arbitrary statement related to the message M . From a practical point of view, integrating Greco inside an application doesn't necessarily force the integrator to modify the logic of the circuit. Instead, the circuit defining the application-specific requirements of the M can be treated as a separate component, independent from Greco.

The flow for the secret voting application can be as follows:

- Voter produces a proof π_1 that M satisfies is either a 1 or 0 that outputs $H = \text{hash}(M, \text{salt})$.
- Voter produces a proof π_2 of correct encryption of the message using Greco circuit. On top of that, the circuit also outputs $H = \text{hash}(M, \text{salt})$.
- Verifier would check that:
 - π_1 verifies
 - π_2 verifies
 - The public output of π_1 matches the public output of π_2

Note that the circuit underlying the generation of π_2 can be written in any language or prover framework available.

7 Benchmarks

All the benchmarks were run on an M2 Macbook Pro with 12 cores and 32GB of RAM. All the benchmarks can be reproduced from the open source code provided. The key benches extracted relate to the setup (pk and vk generation), proof generation and proof verification phases. The parameters have been chosen targeting 128-bit security level for different values of 'n'. For more information on parameters choice, please refer to [Alb+22]

n	$\log q_i$	k	VK Gen Time	PK Gen Time	Proof Gen Time	Proof Ver Time
1024	27	1	376.95s	82.86ms	685.51ms	3.66ms
2048	53	1	771.24ms	186.79ms	1.39s	3.74ms
4096	55	2	2.16s	579.86ms	3.47s	5.02 ms
8192	55	4	5.05s	1.82s	8.98s	4.18ms
16384	54	8	17.59s	7.10s	29.43s	6.97ms
32768	59	15	64.95s	29.33s	102.15s	14.06ms

Table 1: Greco performance benchmarks for different security parameters.

The setup time seems to grow linearly with n as it roughly doubles everytime n doubles. Proof Generation shows a sublinear growth when compared to the growth of n .

The main cost center of the proof generation in terms of constraints is dominated by the Range Checks. In particular, analyzing the number of constraints when n is set to 4096 the

distribution is described in Figure 2. The second most expensive operation is the Evaluation at Gamma Constraint followed by the Phase 0 polynomial assignment. Both grow linearly with n . The constraints required to enforce Phase 1 assignment and Correct Encryption are irrelevant to the overall cost model. Such data can be reproduced by running the Generate Parameters python script available made available through the open source repository.

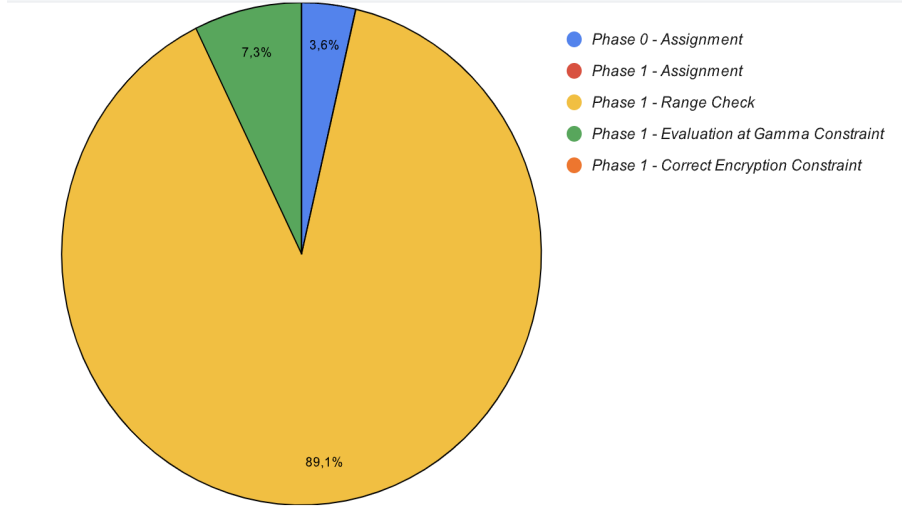

Figure 2: Constraints distribution

8 Conclusions

In this write-up, we have detailed the design and implementation of the Greco prover system, showcasing its utility in verifying the correct formation of Fully Homomorphic Encryption (FHE) ciphertexts. The importance of such system is paramount in multi-party applications such as voting. In such application, Greco can be composed with application-specific circuits that require to prove additional properties on the message being encryption or on the author of such encryption. The benchmarks provide a practical reference for its deployment in real-world scenarios. In order to increase the prover performance, proof systems capable of supporting larger lookup tables such as [a1623], may further speed up the range checks constraints, which are the larger cost center of Greco. A further step is to adapt the techniques described above to other FHE schemes, such as CKKS or TFHE/FHEW. In particular, in CKKS, the message needs to be encoded using FFT, which is not trivial to prove.

9 Acknowledgements

I thank Yuriko Nishijima for the work on the original library [BN23] that inspired Greco. I thank Janmajaya Mall for suggesting leveraging CRT to decompose the ciphertext and coming up with the core matrix definition of the constraint enforced by Greco. I thank Xiang Xie for pointing out a flaw in how the benchmarks were designed.

References

- [a1623] a16z. *lasso*. 2023. URL: <https://github.com/a16z/jolt>.
- [Alb+22] Martin Albrecht et al. “Homomorphic encryption standard”. In: 2022. DOI: 10.1007/978-3-030-77287-1_2.
- [Axi23a] Axiom. *halo2-lib*. 2023. URL: <https://github.com/axiom-crypto/halo2-lib>.
- [Axi23b] Axiom. *Overview of the Halo2 Challenge API and Random Linear Combinations (RLC) Comment*. 2023. URL: <https://hackmd.io/@axiom/SJw3p-qX3>.
- [Baj+17] Jean Claude Bajard et al. “A Full RNS Variant of FV Like Somewhat Homomorphic Encryption Schemes”. In: vol. 10532 LNCS. 2017. DOI: 10.1007/978-3-319-69453-5_23.
- [BN23] Enrico Bottazzi and Yuriko Nishijima. *zk-fhe*. 2023. URL: <https://github.com/enricobottazzi/zk-fhe>.
- [Bra12] Zvika Brakerski. “Fully homomorphic encryption without modulus switching from classical GapSVP”. In: vol. 7417 LNCS. 2012. DOI: 10.1007/978-3-642-32009-5_50.
- [FV12] Junfeng Fan and Frederik Vercauteren. “Somewhat Practical Fully Homomorphic Encryption”. In: *Proceedings of the 15th international conference on Practice and Theory in Public Key Cryptography* (2012).
- [HPS19] Shai Halevi, Yuriy Polyakov, and Victor Shoup. “An Improved RNS Variant of the BFV Homomorphic Encryption Scheme”. In: vol. 11405 LNCS. 2019. DOI: 10.1007/978-3-030-12612-4_5.
- [Inf21] Inferati. *Introduction to the BFV encryption scheme*. 2021. URL: <https://www.inferati.com/blog/fhe-schemes-bfv>.
- [KPZ21] Andrey Kim, Yuriy Polyakov, and Vincent Zucca. “Revisiting Homomorphic Encryption Schemes for Finite Fields”. In: vol. 13092 LNCS. 2021. DOI: 10.1007/978-3-030-92078-4_21.
- [PLS19] Rafael del Pino, Vadim Lyubashevsky, and Gregor Seiler. “Short Discrete Log Proofs for FHE and Ring-LWE Ciphertexts”. In: vol. 11442 LNCS. 2019. DOI: 10.1007/978-3-030-17253-4_12.
- [Sun22] Sunscreen. *sunscreen*. 2022. URL: <https://github.com/Sunscreen-tech/Sunscreen>.
- [Zam23] Zama. *fhEVM Whitepaper*. 2023. URL: <https://github.com/zama-ai/fhevm/blob/main/fhevm-whitepaper.pdf>.

A Appendix

The fact that Q and t are co-prime guarantees that the multiplicative inverse of t modulo Q exists. If Q and t are co-prime, it means their greatest common divisor (GCD) is 1, i.e., $\gcd(Q, t) = 1$. The existence of the multiplicative inverse of $t \pmod Q$ can be understood using Bezout’s Identity, which states that for two integers a and b for which $\gcd(a, b) = d$, then there exists integers such that $ax + by = d$. In this case $Qx + ty = 1$, $ty = 1 - Qx$, $ty = 1 \pmod Q$. y in this case is the multiplicative inverse of t modulo Q and this guarantees its existence. The

fact that Q and t are co-prime guarantees that the division has a remainder. That remainder is actually equal to $[QM]_t$. In this way, we can cancel out the $[\]$ notation.

B Appendix

Let's consider the multiplication of two polynomials $F(x) * G(x) = H(x)$. F and G are polynomial of equal degree n . While polynomial H will have degree $2n$

$$F(x) = a_n x^n + a_{n-1} x^{n-1} + \dots + a_1 x + a_0$$

$$G(x) = b_n x^n + b_{n-1} x^{n-1} + \dots + b_1 x + b_0$$

$$H(x) = c_n x^{2n} + c_{n-1} x^{2n-1} + \dots + c_1 x + c_0$$

The coefficients of H are calculate as follows: $c_k = \sum_{i+j=k} a_i \cdot b_j$ The sum is taken over all the pairs a_i and b_j such that the sum of the indexes is equal to k . For values of k such that $k < n$ the number of pairs (i, j) such that $i + j = k$ increas as k increases. This is intuitive because there are more ways to partition a number into two non-negative integers as the number increases. In particular for $k = 0$ there's gonna be 1 pair (= 1 multiplication and 0 additions), while for $k = n - 1$, there's gonna be n pairs (= n multiplications and $n - 1$ additions). At $k = n$ there's the maximum number of pairs (i, j) such that $i + j = k$. Specifically, there are $n + 1$ pairs that satisfy this condition. In particular for $k = n$ there's gonna be $n + 1$ pairs (= $n + 1$ multiplications and n additions). For values of k such that $k > n$ the number of pairs (i, j) such that $i + j = k$ decreases as k increases. This is because the maximum value that i and j can take is n . So the number of pairs starts to decrease. Think of $k = 2n$; in that case, there's only one pair, which is $(i = n, j = n)$. In particular for $k = n + 1$, there's gonna be n pairs (= n multiplications and $n - 1$ additions) and for $k = 2n$ there's gonna be 1 pair (= 1 multiplication and 0 additions)

In total there's gonna be $2 * (\sum_{i=0}^{n-1} i + 1) + (n + 1)$ multiplications and $2 * (\sum_{i=0}^{n-1} i) + n$ additions. When simplified $2 * \frac{n(n+1)}{2} + (n+1) = (n+1)^2$ multiplications and $2 * \frac{n(n-1)}{2} + n = n^2$ additions

C Appendix

- $R_{2,i} = [-\frac{q_i-1}{2}, \frac{q_i-1}{2}]$ since the operation is performed $\pmod{Z_{q_i}}$
- $A_i = [-\frac{q_i-1}{2}, \frac{q_i-1}{2}]$
- $S = [-1, 1]$
- $deg(A_i) = N - 1$.
- $deg(S) = N - 1$.
- $A_i S = [-N \cdot \frac{q_i-1}{2}, N \cdot \frac{q_i-1}{2}]$.

That's true because of the following. Let's consider the multiplication of two polynomials $F(x) * G(x) = H(x)$. F and G are polynomial of equal degree n . Assume that the coefficients of F and G are in the range $[0, Q)$

$$F(x) = a_n x^n + a_{n-1} x^{n-1} + \dots + a_1 x + a_0$$

$$G(x) = b_n x^n + b_{n-1} x^{n-1} + \dots + b_1 x + b_0$$

$$H(x) = c_n x^{2n} + c_{n-1} x^{2n-1} + \dots + c_1 x + c_0$$

The coefficients of H are calculate as follows: $c_k = \sum_{i+j=k} a_i \cdot b_j$. The sum is taken over all the pairs a_i and b_j such that the sum of the indexes is equal to k . Now, let's determine which c_k will have the most elements in its sum.

- For values of k such that $k < n$ the number of pairs (i, j) such that $i + j = k$ increas as k increases. This is intuitive because there are more ways to partition a number into two non-negative integers as the number increases.
- For values of k such that $k > n$ the number of pairs (i, j) such that $i + j = k$ decreases as k increases. This is because the maximum value that i and j can take is n . So the number of pairs starts to decrease. Think of $k = 2n$, in that case there's only one pair which is $(i = n, j = n)$
- At $k = n$ there's the maximum number of pairs (i, j) such that $i + j = k$. Specifically, there are $n + 1$ pairs that satisfy this condition.

Given the case in which $A_i = [-\frac{q_i-1}{2}, \frac{q_i-1}{2}]$, $S = [-1, 1]$, $deg(A_i) = N-1$ and $deg(S) = N-1$.

When performing the polynomial multiplication, let's consider the case in which the coefficients of A_i are all $(q_i - 1)/2$ and the coefficients of S_i are all 1, $c_n = \sum_{j=0}^{n-1} a_j * s_{n-j}$, $max(c_n) = \frac{q_i-1}{2} \cdot 1 \cdot N$ and $min(c_n) = \frac{q_i-1}{2} \cdot -1 \cdot N$

Therefore:

- $E = [-B, B]$
- $A_i S + E = [-(N \cdot \frac{q_i-1}{2} + B), N \cdot \frac{q_i-1}{2} + B]$
- $K_1 = [-\frac{t-1}{2}, \frac{t-1}{2}]$
- $K_{0,i} = -(t^{-1} \text{ mod } q_i)$. Note: this is a (negative) scalar, not a polynomial
- $K_{0,i} K_1 = K_i = [-\frac{t-1}{2} \cdot |K_{0,i}|, \frac{t-1}{2} \cdot |K_{0,i}|]$
- $A_i S + E + K_i = C\hat{t}_{0,i} = [-(N \cdot \frac{q_i-1}{2} + B + \frac{t-1}{2} \cdot |K_{0,i}|), N \cdot \frac{q_i-1}{2} + B + \frac{t-1}{2} \cdot |K_{0,i}|]$
- $deg(C\hat{t}_{0,i}) = 2N - 2$.
- $Ct_{0,i} = [-\frac{q_i-1}{2}, \frac{q_i-1}{2}]$
- $R_{2,i} = [-\frac{q_i-1}{2}, \frac{q_i-1}{2}]$
- $R_{2,i}(X^N + 1) = [-\frac{q_i-1}{2}, \frac{q_i-1}{2}]$

That's true because of the following polynomial multiplication:

- $R_{2,i} = [-(q_i - 1)/2, (q_i - 1)/2]$.
- $deg(X^N + 1) = N$

- $\deg(R_{2,i}) = 2(N - 1) - N = N - 2$
- $\deg(R_{2,i} * (X^N + 1)) = 2N - 2$

When performing the polynomial multiplication, let's consider the case in which the coefficients of $R_{2,i}$ are all $(q_i - 1)/2$, and let's define the polynomial $(X^N + 1)$ as f .

The results of the multiplication between any coefficient of $R_{2,i}$ with the leading coefficient of f ($=1$) will contribute to the summation of the resulting polynomial coefficients of degree from $2N - 2$ when the leading coefficient of $R_{2,i}$ is multiplied with the leading coefficient of f , to N , when the constant term of $R_{2,i}$ is multiplied with the leading coefficient of f .

The results of the multiplication between any coefficient of $R_{2,i}$ with the constant term of f ($=1$) will contribute to the summation of the resulting polynomial coefficients of degree from $N - 2$ when the leading coefficient of $R_{2,i}$ is multiplied with the constant term of f , to 0, when the constant term of $R_{2,i}$ is multiplied with constant term of f .

Given that all the other coefficients of f are equal to 0, the multiplication between the coefficients of $R_{2,i}$ and these coefficients of f won't contribute to the summation of any of the resulting polynomial coefficients.

We also note that the results of the multiplication between any coefficient of $R_{2,i}$ with the leading coefficient of f and the results of the multiplication between any coefficient of $R_{2,i}$ with the constant term of f ($=1$) won't ever be added together in the summation to calculate one of the resulting polynomial coefficients.

Therefore, it can be concluded that the range of the resulting polynomial is the same as the range of the $R_{2,i}$ polynomial.

- $Ct_{0,i} - \hat{C}t_{0,i} = [-((N+1) \cdot \frac{q_i-1}{2} + B + \frac{t-1}{2} \cdot |K_{0,i}|), (N+1) \cdot \frac{q_i-1}{2} + B + \frac{t-1}{2} \cdot |K_{0,i}|]$
- $Ct_{0,i} - \hat{C}t_{0,i} - R_{2,i}(X^N + 1) = [-((N+2) \cdot \frac{q_i-1}{2} + B + \frac{t-1}{2} \cdot |K_{0,i}|), (N+2) \cdot \frac{q_i-1}{2} + B + \frac{t-1}{2} \cdot |K_{0,i}|]$
- $R_{1,i} = \frac{Ct_{0,i} - \hat{C}t_{0,i} - R_{2,i}(X^N + 1)}{q_i} = [\frac{-((N+2) \cdot \frac{q_i-1}{2} + B + \frac{t-1}{2} \cdot |K_{0,i}|)}{q_i}, \frac{(N+2) \cdot \frac{q_i-1}{2} + B + \frac{t-1}{2} \cdot |K_{0,i}|}{q_i}]$